

GRANITOGRES

GRÈS FINE PORCELLANATO

2/2



CASALGRANDE
PADANA
Pave your way



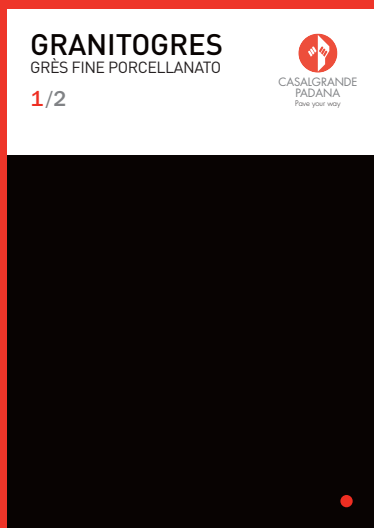

1/2



2/2 ↑



GRANITOGRES

GRES FINE PORCELLANATO

GRANITOGRES

GRES FINE PORCELLANATO

2/2

08

serie Marmogres

24

serie Marte

54

serie Nuvolato

56

serie Pietre Rare

64

serie Titano

74

serie Agorà

78

serie Ardesia

84

serie Natural Slate

88

serie Pietre Runiche

92

serie Tibertino

96

Caratteristiche tecniche
 Technical features
 Caractéristiques techniques
 Technische Eigenschaften

98

Pesi, misure e contenuto dei colli
 Weight, size and contents of the packing
 Poids, dimensions, contenu des colis
 Verpackungsgrößen/Gewichte

100

Posa e manutenzione
 Installation and maintenance
 Pose et entretien
 Verlegen und pflege



Granitogres è l'espressione evoluta del grès porcellanato pienamente vetrificato non smaltato. Utilizzabile sia per pavimenti sia per rivestimenti, Granitogres è la soluzione ideale per luoghi di grande transito, soggetti a forte stress fisico-chimico, ma anche per l'architettura residenziale, specialmente nelle serie più prestigiose, dove la robustezza del materiale è felicemente coniugata ad una grande raffinatezza estetica. Idoneo sia ad ambienti asciutti che umidi o bagnati (nella superficie specifica), Granitogres è disponibile in diverse superfici: naturale, levigata, satinata, honed, gloss e strutturata. La vastissima gamma di colori, formati e pezzi speciali consente ad architetti e progettisti la massima libertà di scelta. Granitogres è adatto ad ogni soluzione progettuale, dalle più originali costruzioni di architettura moderna al restauro di edifici classici. Per le elevate qualità tecniche, l'estrema semplicità di posa in opera, la massima facilità di manutenzione, Granitogres è ovunque la scelta ideale!

Granitogres is the evolved expression of fully vitrified unglazed porcelain stoneware. Granitogres can be used both for floor and wall tiling, and is the ideal solution for high traffic places, with significant physical-chemical stress, but can also be used for residential architecture: the most prestigious lines, successfully matching sturdiness and a great esthetical refinement, are especially indicated for these uses. Granitogres is suitable both for dry and wet or humid rooms (in the specific surface) and is available in several natural and relief surfaces. The huge range of colours, sizes, surfaces and special pieces enables the widest choice of solutions, combinations and applications to architects and designers. Granitogres is suitable for every design solution, from the most original building of modern architecture to the restoration of classical buildings. Thanks to its superior technical features, extremely easy laying and convenient maintenance, Granitogres is the ideal choice always!

Granitogres est l'expression la plus évoluée du grès cérame totalement vitrifié pas émaillé. Utilisable pour des carrelages de sol et muraux, Granitogres est la solution idéale à la fois pour des ambiances très fréquentées soumis à de fortes sollicitations physicochimiques et pour des constructions à usage d'habitation. En ce cas, en particulier, sont conseillées les séries les plus prestigieuses dans lesquelles la solidité du matériau s'unit à la grande élégance esthétique en une association de succès. Indiqué pour des ambiances sèches aussi bien qu'humides ou mouillées (dans la surface adéquate), Granitogres est disponible en plusieurs surfaces, naturelles et structurées. La très vaste gamme de couleurs, de formats, de surfaces et de pièces spéciales donne aux architectes et aux designers une grande possibilité de choix. Granitogres s'adapte à toutes les solutions architectoniques, à partir des plus originales constructions de l'architecture moderne jusqu'à la restauration de bâtiments classiques. Pour ses qualités techniques remarquables, pour l'extrême simplicité de pose, pour la grande facilité d'entretien, Granitogres se révèle de toute manière le choix idéal!

Granitogres ist eine weiterentwickelte Form des voll glasgebrannten nicht glasierten Feinsteinzeuges. Granitogres-Boden- und Wandfliesen, sind die echte Lösung für stark betretene Bereiche, die hohen physisch-chemischen Belastungen ausgesetzt sind, aber auch für die Wohnarchitektur. Dies gilt insbesondere für die kostbareren Serien, wo Materialstärke und optische Schönheit bestens ineinander verfließen. Für trockene, feuchte und nasse Bereiche (mit geeigneter Oberflächenstruktur) steht Granitogres in verschiedenen natürlichen oder strukturierten Oberflächen zur Verfügung. Die weite Palette von Farben, Formaten, Oberflächen und Formteilen verleiht den Architekten und Planern höchste Freiheit in der Wahl, Kombination und Benutzung dieser Elemente. Granitogres eignet sich bestens für jegliche Art von Projekt, von den originellsten Gebäuden der modernen Architektur bis zur Renovierung der klassischen Gebäude.

L'AZIENDA
THE COMPANY
LA SOCIÉTÉ
DER BETRIEB



Casalgrande Padana nasce nel 1960.

Prima azienda in Italia a focalizzare la propria produzione sul grès porcellanato, ha conosciuto uno straordinario trend di crescita, fino ad occupare una posizione di assoluto rilievo internazionale, contando oggi più di cinquecento dipendenti, impiegati in quattro stabilimenti. Da sempre la strategia di Casalgrande Padana è orientata alla qualità totale, ciò non significa solo garantire elevati standard qualitativi del prodotto e del servizio, ma soprattutto impegnarsi quotidianamente per migliorare a piccoli passi tutti i processi produttivi e di servizio al cliente. La costante ricerca dell'eccellenza, unita ad importanti investimenti tecnologici, consente a Casalgrande Padana di offrire ai propri clienti una gamma di piastrelle universali, ideali per pavimenti e rivestimenti, per ambienti ad alto traffico, per spazi residenziali, per il terziario e per l'industria. La ricerca, l'innovazione, la strategia commerciale, l'attenzione all'ambiente e soprattutto i milioni di metri quadrati venduti nel mondo, fanno di Casalgrande Padana un sinonimo di qualità e affidabilità.

Casalgrande Padana was established in 1960.

It has been the first company in Italy to focus on the production of porcelain stoneware, and has experienced an outstanding growth trend, till getting a top position worldwide. Casalgrande Padana has today over 500 employees in four factories. The policy by Casalgrande Padana has always been dedicated to total quality. This does not only mean ensuring high quality standards for the product and the service, but above all a daily commitment to improve gradually all the production and customer service processes. The steady research combined with significant technological investments enable Casalgrande Padana to offer its customers a range of universal tiles, ideal for floors and walls, high traffic places, residential uses, industry and service sectors. The research combined with innovation, commercial strategy and environment care and, above all, the millions of square metres sold all over the world make Casalgrande Padana a synonym for quality and reliability.

LE LINEE

Granitogres, Granitogres Rusticato e Pietre Native fanno di Casalgrande Padana un leader mondiale nella produzione di grès porcellanato non smaltato.

Si tratta di prodotti dalle altissime prestazioni tecniche e strutturali, che assicurano la massima praticità nella realizzazione della posa in opera e delle finiture, oltre ad un'estrema facilità di manutenzione e una durata illimitata nel tempo. Ma Casalgrande Padana è anche **Granitoker** e **Gresplus**, grès porcellanato smaltato, che coniugano le possibilità estetiche degli smalti alle prestazioni eccezionali del supporto in porcellanato; **Ecogres**, la linea di monocottura, offre un'ampia gamma di colori e formati e una notevole varietà di complementi, decori e pezzi speciali. Per l'edilizia industriale, dei servizi, commerciale e residenziale, Casalgrande Padana è la soluzione ideale per forza, praticità e bellezza, per sempre.

THE LINES

Granitogres, Granitogres Rusticato and **Pietre Native** make Casalgrande Padana a worldwide leader in the production of unglazed porcelain stoneware. These products have a superior technical and structural performance, ensure the top practicality in the laying and finishing, are extremely easy to maintain and last forever. But Casalgrande Padana is also **Granitoker** and **Gresplus**, glazed porcelain stoneware, which match the esthetical possibilities of the glazes with the outstanding performance of the porcelain support; **Ecogres**, the single-firing line, offers a wide range of colours and sizes, as well as accessories, decorations and special pieces. Casalgrande Padana is the ideal solution for the industrial, service, commercial and residential building thanks to its everlasting strength, practicality and beauty.



© Franco Formica

LES LIGNES

Granitogres, Granitogres Rusticato et Pietre Native ont transformé Casalgrande Padana en leader mondial de la production de grès cérame non émaillé. Il s'agit de deux produits aux performances techniques et structurelles remarquables qui assurent le maximum de commodité lors de la réalisation de la pose et des finitions, outre à garantir une facilité exceptionnelle d'entretien et une durée illimitée dans le temps. Casalgrande Padana est aussi **Granitoker** et **Gresplus**, grès cérame émaillé, qui combinent les possibilités esthétiques des émaux et les performances supérieures du support en grès cérame; **Ecogres**, ligne monocuisson, offre une vaste gamme de couleurs et de formats et dispose d'une variété notable de compléments, de décors et de pièces spéciales. Pour le secteur des constructions industrielles, de services, commerciales et à usage d'habitation, Casalgrande Padana est la solution idéale quant à force, praticité et beauté. Pour toujours.

DIE LINIEN

Granitogres, Granitogres Rusticato und Pietre Native machen aus Casalgrande Padana einen internationalen Führer in der Produktion von unglasiertes Feinsteinzeug. Es handelt sich um Produkte mit hohen technischen und strukturbezogenen Leistungen, welche maximale Zweckmäßigkeit beim Legen und Fertigbearbeiten gewährleisten; dazu kommt die extreme Pflegeleichtigkeit, die eine lange Lebensdauer verspricht. Aber Casalgrande Padana ist auch **Granitoker** und **Gresplus**, glasiertes Feinsteinzeug, die die ästhetische Kraft der Glasuren mit den hohen Leistungen des Feinsteinzeugs vereinigen.

Ecogres, die Linie der Einbrandfliesen, bietet eine große Reihe von Farben und Formaten und eine breite Auswahl an Zubehörteilen, Dekoren und Formteilen. Casalgrande Padana verkörpert die perfekte und definitive Lösung in Punkto Widerständigkeit, Zweckmäßigkeit und Schönheit im Bereich der Bauindustrie, der Dienstleistungen, der Handelszentren und des Wohnungsbaus.

Créée en 1960, Casalgrande Padana a été la première société italienne à focaliser toute son attention sur la production de grès cérame. Depuis, Casalgrande Padana a toujours poursuivi une tendance de croissance importante jusqu'à occuper une position de premier rang au niveau international. Casalgrande Padana occupe aujourd'hui plus de 500 personnes qui travaillent dans ses quatre établissements. Depuis toujours, la stratégie adoptée par Casalgrande Padana est orientée vers la qualité totale; ce qui signifie non seulement garantir des standards élevés en termes de qualité du produit et du service, mais aussi s'engager quotidiennement à améliorer, petit à petit, tous les procédés productifs et tous les services au client. La poursuite constante de l'excellence, unie à des investissements importants dans le domaine technologique, permet à Casalgrande Padana d'offrir à ses clients une gamme de carreaux universels, idéaux comme carrelages de sol et muraux pour des ambiances très fréquentées et des constructions à usage d'habitation, pour le tertiaire et l'industrie. La recherche, l'innovation, la stratégie commerciale, l'attention à l'environnement et surtout les millions de mètres carrés vendus dans le monde entier font de Casalgrande Padana un synonyme de qualité et de fiabilité.

Casalgrande Padana wurde im Jahre 1960 gegründet. Es handelt sich um den ersten Betrieb in Italien, dessen Produktion komplett dem Feinsteinzeug gewidmet wurde. Daraus hat diese Firma einen großen Aufschwung erfahren, bis sie auf internationaler Ebene eine sehr wichtige Position eingenommen hat. Heute zählt Casalgrande Padana mehr als 500 Beschäftigte, die in vier Werken tätig sind. Seit je her orientiert sich die Strategie der Firma Casalgrande Padana nach der totalen Qualität: das bedeutet nicht nur höchste Produkt- und Dienstleistungsqualität, sondern auch tagtägliches und schrittweises Verbessern der Produktionsverfahren und der Kundendienstleistungen. Die ständige Suche nach Vollkommenheit zusammen mit wesentlichen technologischen Investitionen, erlauben Casalgrande Padana ihren Kunden eine Reihe universeller Fliesen zu bieten, die für Böden und Wände, für stark betretene Oberflächen, Wohn-, Dienstleistungs- und Industriebereich geeignet sind. In der ganzen Welt ist Casalgrande Padana Synonym für Qualität und Zuverlässigkeit im Sinne der Forschung, der Innovation, der wirtschaftlichen Strategie, der finanziellen Solidität und des Umweltschutzes.



granitogres

serie MARMOGRES

portoro
levigato
polished
cm 60x60



MARMOGRES

MARTE

NUVOLATO

PIETRE RARE

TITANO

AGORÀ

ARDESIA

NATURAL SLATE

PIETRE RUNICHE

TIBURTINO

nero marquinia



portoro



verde india

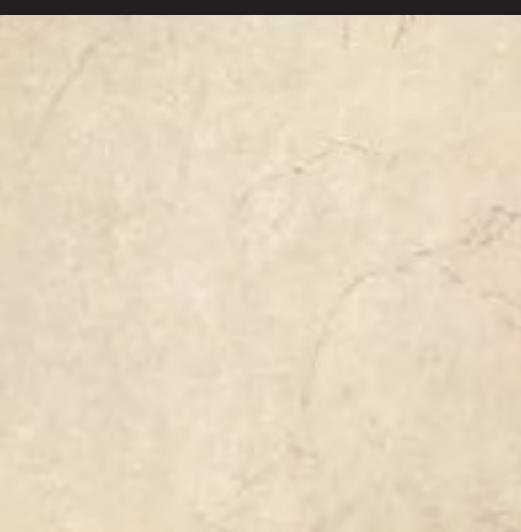
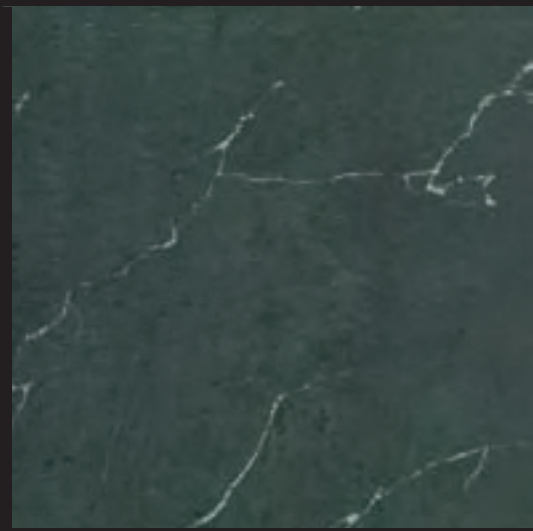

cremo supremo

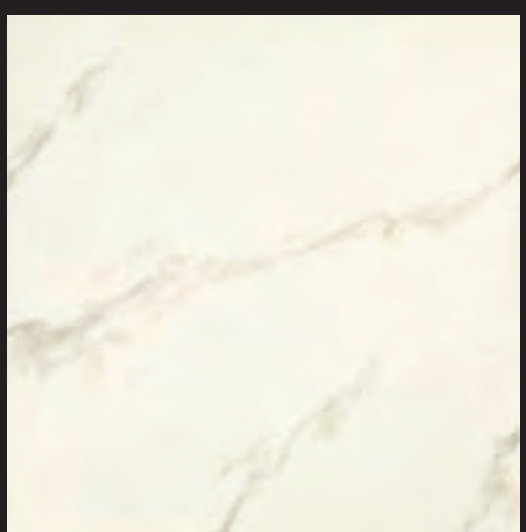

calacatta beige

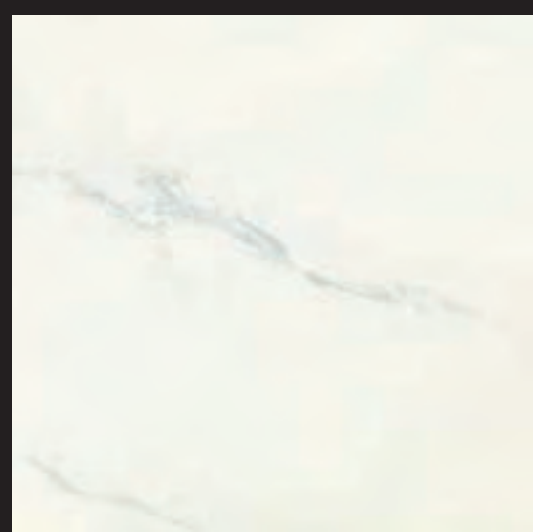

calacatta grigio

rosso laguna

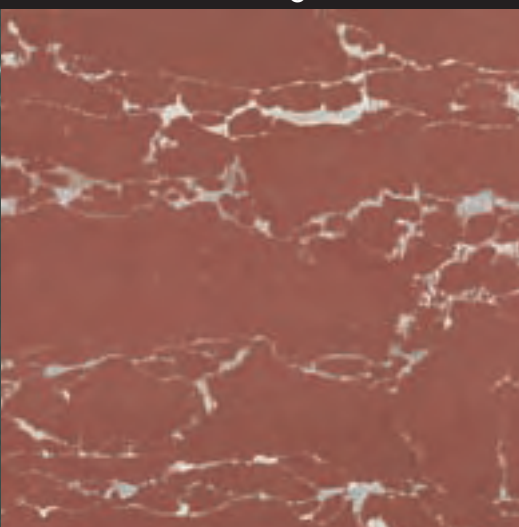

giallo siena

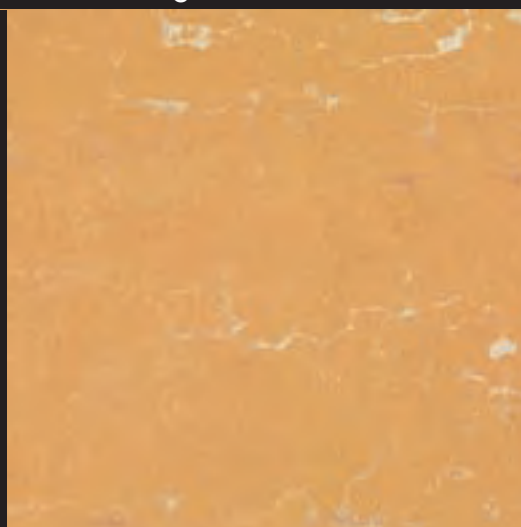

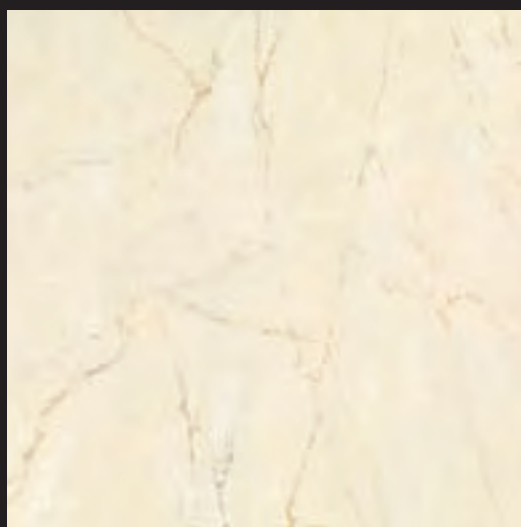

pennsylvania



paonazzetto

TABELLA RIASSUNTIVA FORMATI-SUPERFICI-SPESSORI STANDARD
 TABLE SUMMARISING STANDARD SIZES-SURFACES-THICKNESSES
 TABLEAU RECAPITULATIF DES FORMATS-SURFACES-EPAISSEURS STANDARD
 ZUSAMMENFASSENDE TABELLE STANDARD FORMATE-OBERFLÄCHEN-STÄRKEN

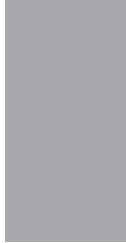
				
	cm 30x30 12"x12"	cm 30x60 12"x24"	cm 60x60 24"x24"	cm 60x120 24"x48"
Calacatta Beige	● ●	● ●	● ●	● ●
Calacatta Grigio	● ●	● ●	● ●	● ●
Crema Supremo	● ● ●	● ● ●	● ● ●	● ● ●
Giallo Siena	● ●	● ●	● ●	● ●
Nero Marquinia	● ● ●	● ● ●	● ● ●	● ● ●
Paonazzetto	● ● ●	● ● ●	● ● ●	● ● ●
Nero Marquinia	● ● ●	● ● ●	● ● ●	● ● ●
Pennsylvania	● ● ●	● ● ●	● ● ●	● ● ●
Portoro	● ●	● ●	● ●	● ●
Laguna Rossa	● ●	● ●	● ●	● ●
Verde India	● ● ●	● ● ●	● ● ●	● ● ●

● Naturale Matt Naturelle Natur ● Levigato Polished Polie Poliert ● Honed

Spessore su superficie naturale Thickness on matt surface Epaisseur sur surface mat Stärke der Fliesen mit Mattoberfläche: **10,5 mm**

Spessore su superficie levigata/honed Thickness on polished/honed surface Epaisseur sur surface polie/honed Stärke der Fliesen mit polierten und honed Oberfläche: **10 mm**

PEZZI SPECIALI TRIMS ACCESSOIRES FORMSTÜCKE

Battiscopa Bullnose
 Plinthe à bord arrondi Stehsockel
cm 9x30 3½"x12"
cm 9x60 3½"x24"

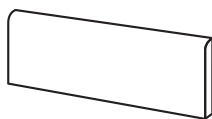

Gradino Step tread
 Nez de marche Stufenplatte
cm 30x30 12"x12"
cm 30x60 12"x24"

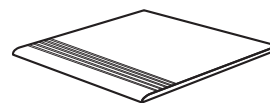

Tozzetto Insert
 Cabochon Einleger
cm 9x9 3½"x3½"

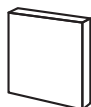

Listello Listel
 Listel Zeilerleiste
cm 9x30 3½"x12"
cm 9x60 3½"x24"



Scalino
cm 60x33 24"x13"

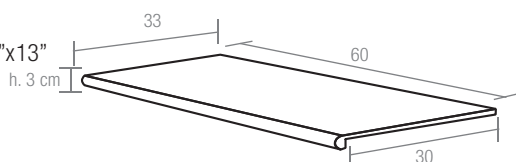

Scalino angolare
cm 60x33 24"x13"

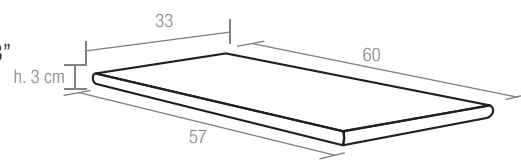



paonazetto, giallo siena levigato polished cm 60x60

MARMOGRES

MARTE

NUVOLATO

PIETRE RARE

TITANO

AGORÀ

ARDESIA

NATURAL SLATE

PIETRE RUNICHE

TIBURTINO



granitogres

MARMOGRES

MARTE

NUVOLATO

PIETRE RARE

TITANO

AGORÀ

ARDESIA

NATURAL SLATE

PIETRE RUNCICHE

TIBURTINO

DECORO RIGHE*



cm 30x60 12"x24"
Nero Marquinia

DECORO STELLE A



cm 30x60 12"x24"
Pennsylvania

DECORO STELLE B



cm 30x60 12"x24"
Nero Marquinia

*Disponibile in tutti i colori della serie Available in all the colours of the series
Disponibile dans tous les couleurs de la série Verfügbar in allen farben



pennsylvania cm 60x60, nero marquinia levigato polished cm 30x60
decoro righe nero marquinia cm 30x60

MOSAICO FLOREALE A



cm 50x50 20"x20"
Nero Marquinia

MOSAICO FLOREALE B

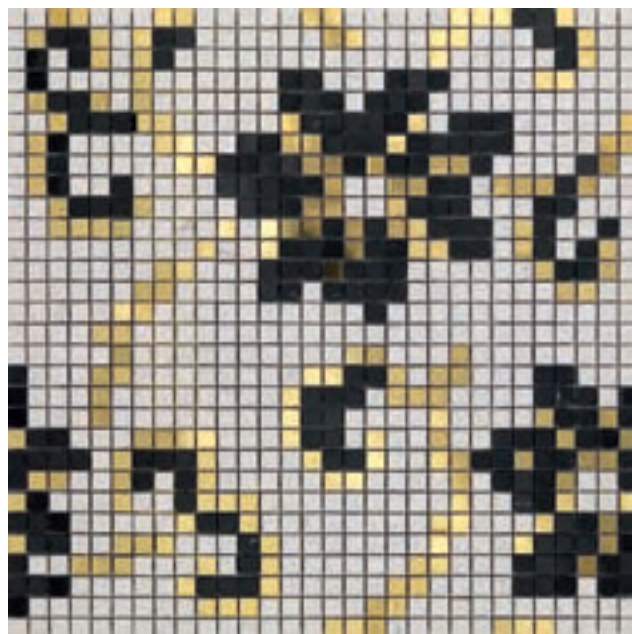

cm 50x50 20"x20"
Pennsylvania

mosaico floreale A cm 50x50, pennsylvania levigato polished cm 60x60

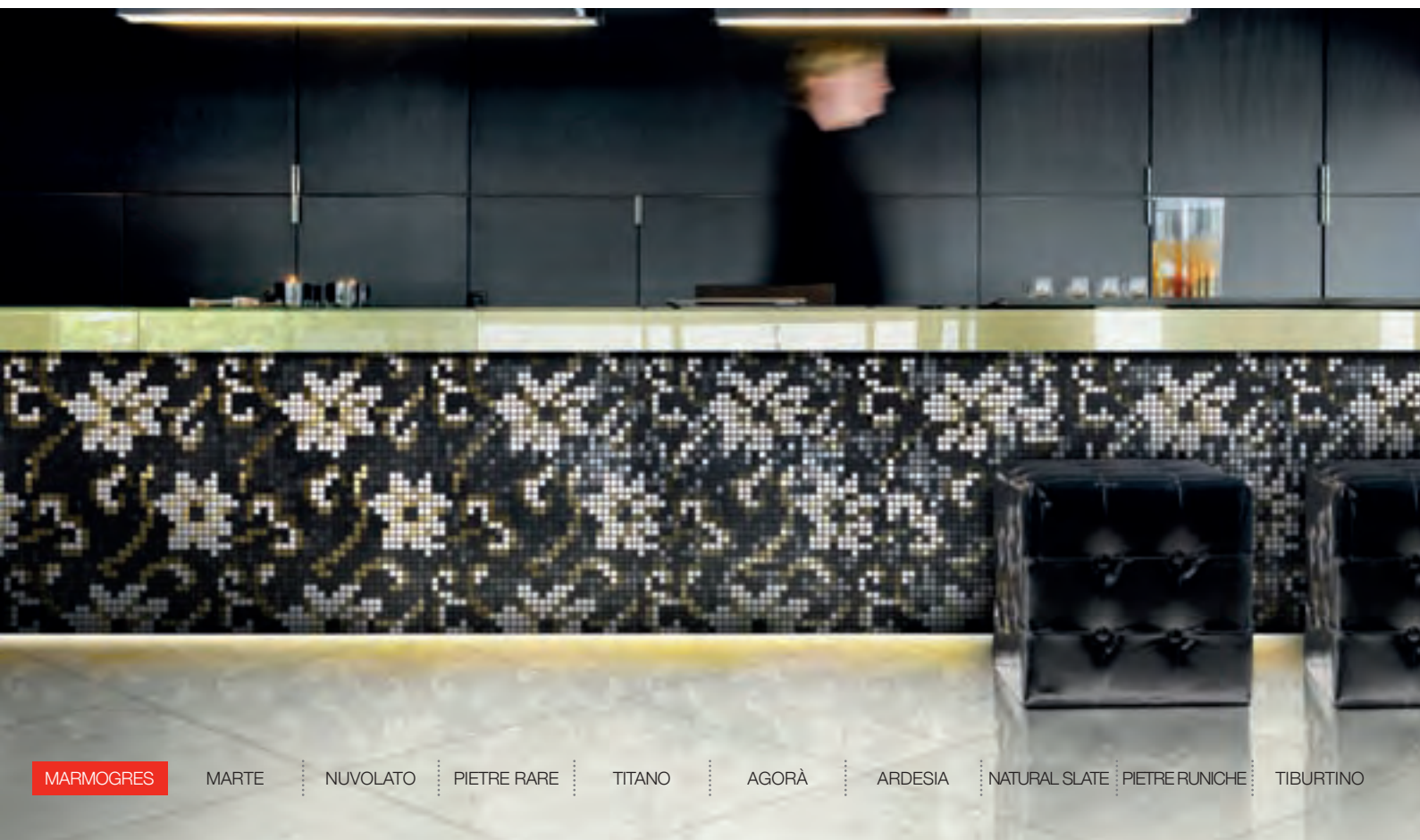

DECORO LISTELLI A



cm 30x60 12"x24"

Paonazzetto, Verde India,
Giallo Siena

DECORO LISTELLI B



cm 30x60 12"x24"

Pennsylvania, Portoro,
Nero Marquinia

DECORO LISTELLI C



cm 30x60 12"x24"

Paonazzetto, Rosso
Laguna, Nero Marquinia

FINITURA DI CHIUSURA LIMIT FINISH FINITION TERMINALE ABSCHLUSSELEMENT

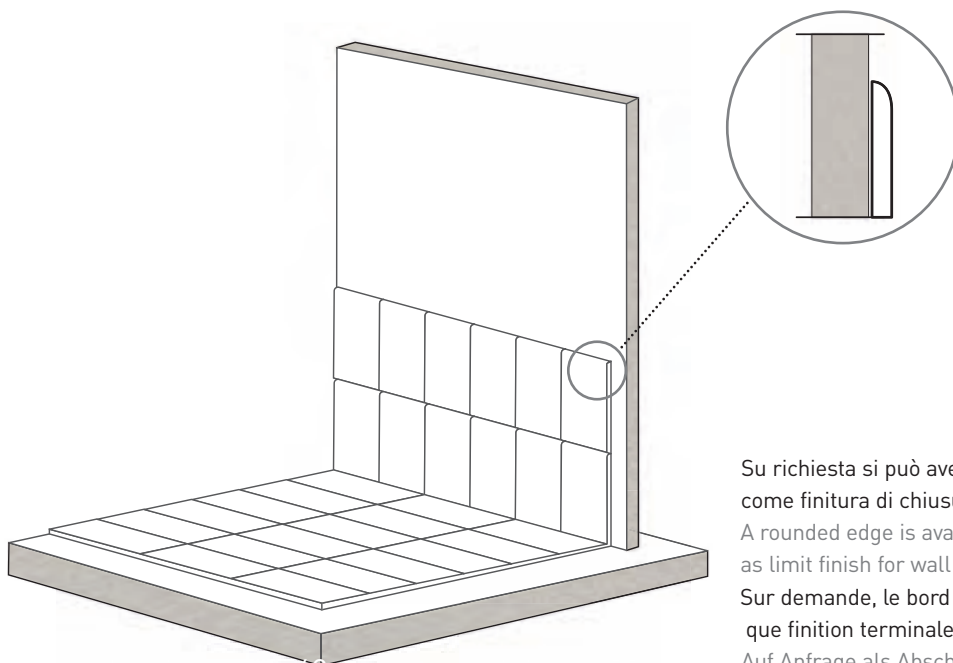

Su richiesta si può avere il bordo arrotondato
come finitura di chiusura per rivestimenti di pareti
A rounded edge is available on request
as limit finish for wall covers

Sur demande, le bord peut être arrondi en tant
que finition terminale pour le revêtement de murs

Auf Anfrage als Abschlusselement für Wandwerkledungen
mit abgerundeter Kante erhältlich

DECORO ONDA*

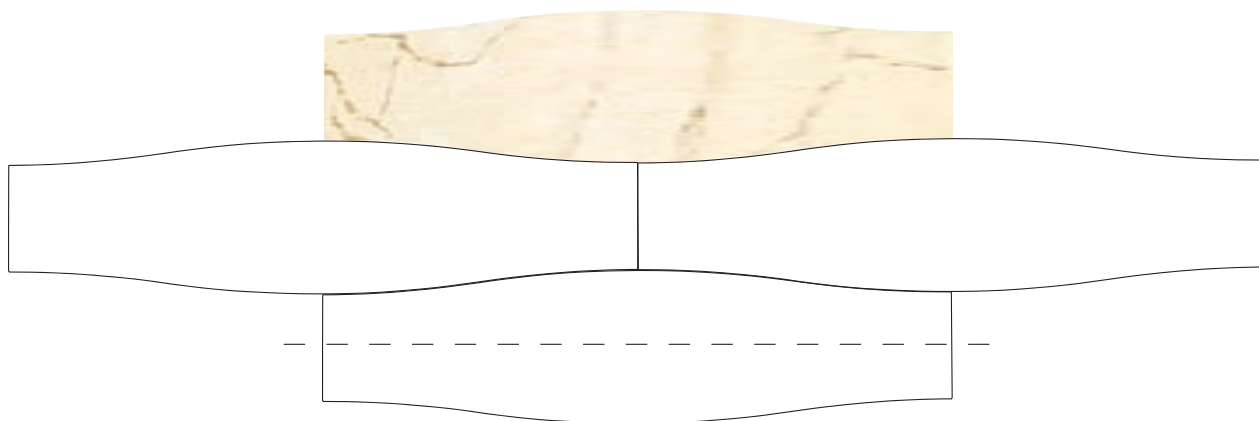

cm 14,6x60 5/8" x24"

*Disponibile in tutti i colori della serie
Available in all the colours of the series
Disponibile dans tous les couleurs de la série
Verfügbar in allen Farben

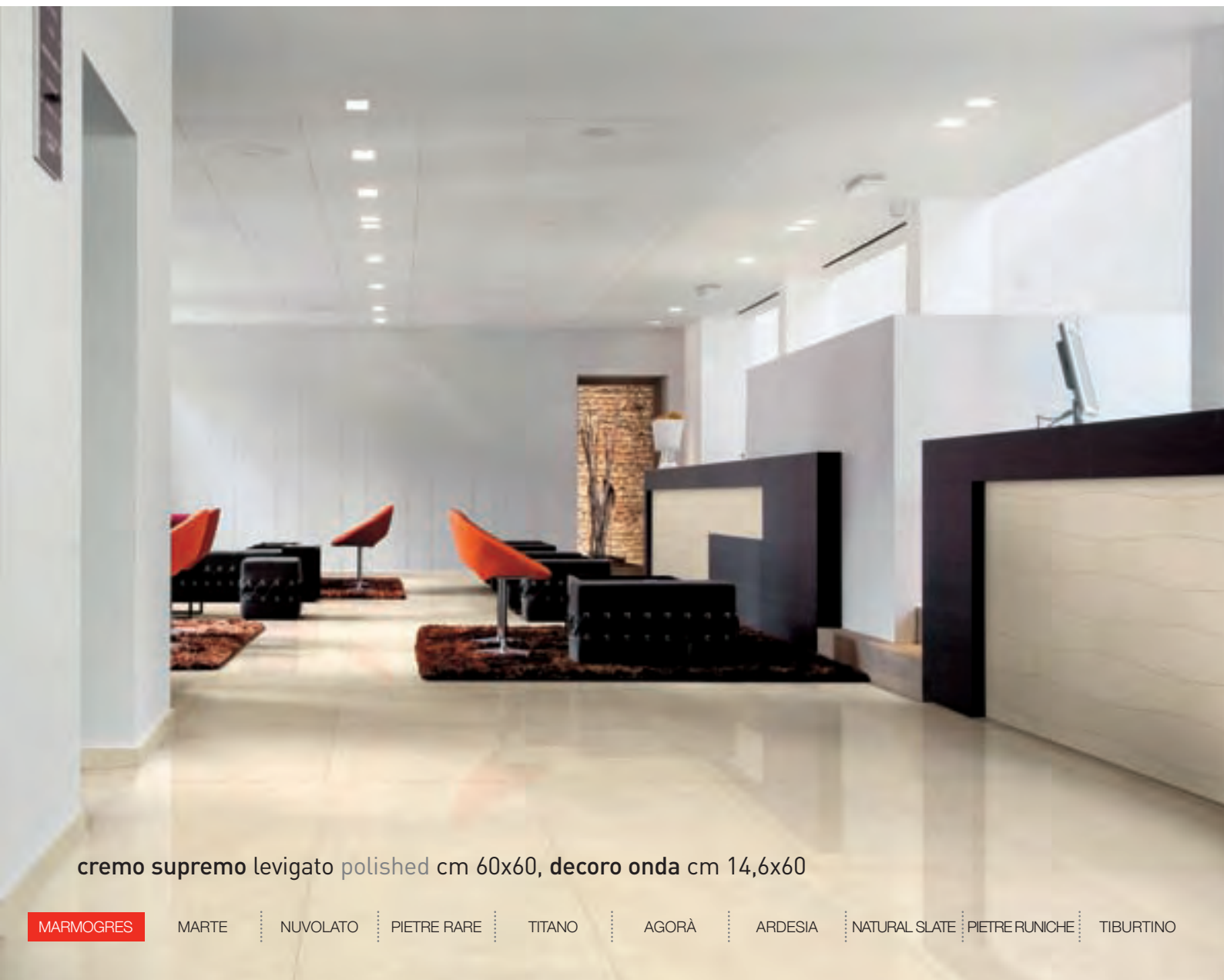

cremo supremo levigato polished cm 60x60, decoro onda cm 14,6x60



rosso laguna, paonazetto levigato polished cm 30x60
mosaico rosso laguna cm 30x30, decoro listelli C cm 30x60

MOSAICO SCACCHIERA A

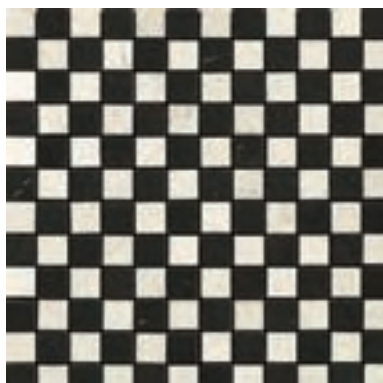

cm 30x30 12"x12"

su rete on net sur trame auf Netz

Nero Marquinia,
Pennsylvania

MOSAICO SCACCHIERA B

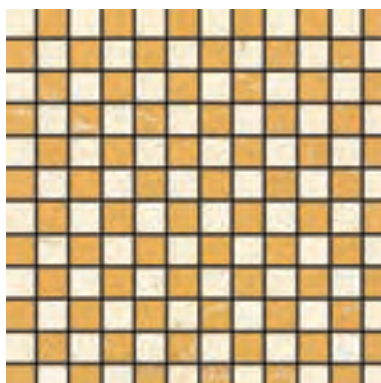

cm 30x30 12"x12"

su rete on net sur trame auf Netz

Giallo Siena, Paonazzetto

MOSAICO TRIANGOLO A



cm 30x30 12"x12"

su rete on net sur trame auf Netz

Nero Marquinia,
Pennsylvania

MOSAICO TRIANGOLO B



cm 30x30 12"x12"

su rete on net sur trame auf Netz

Giallo Siena, Paonazzetto

MOSAICO*

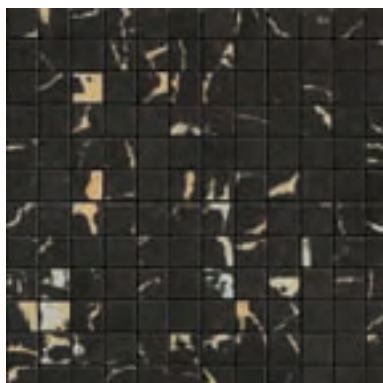

cm 30x30 12"x12"

su rete on net sur trame auf Netz

*Disponibile nei colori
Available in the colours
Disponibile dans les couleurs
Verfügbar in den folgenden Farben:
Portoro,
Rosso Laguna,

ROSONE CLASSICO MARMOGRES

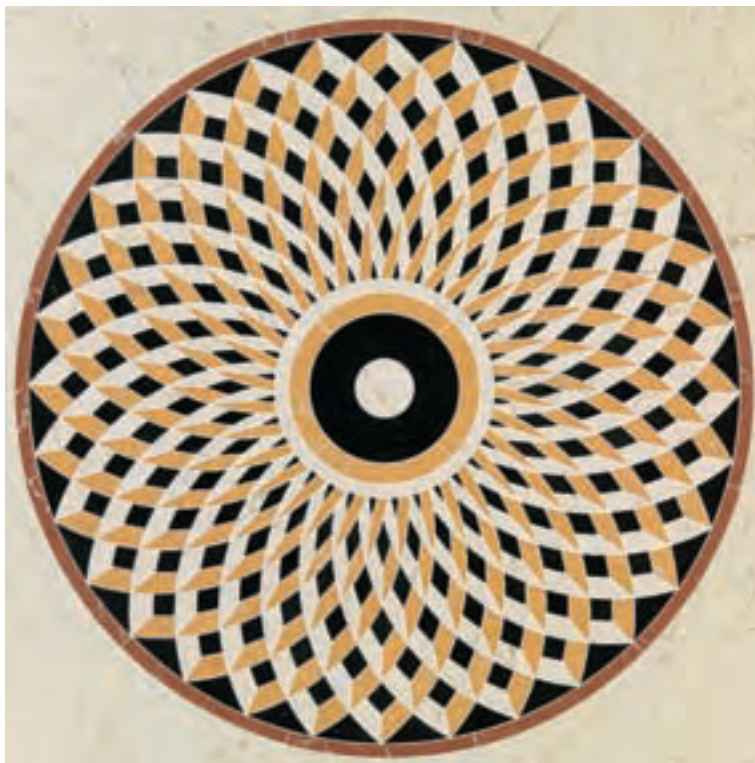

cm 180x180 72"x72"

Giallo Siena, Paonazzetto, Nero Marquinia, Rosso Laguna

ROSONE FLOREALE MARMOGRES



cm 240x120 96"x48"

Paonazzetto, Pennsylvania, Portoro, Rosso Laguna, Giallo Siena, Verde India

SUPERFICI SURFACES SURFACES OBERFLÄCHEN

granitogres

levigata
polished
polie
poliert

honed

naturale
matt
naturel
matt

granitogres

serie MARTE

raggio di luna
grigio maggia
bocciardato
cm 30x30



MARMOGRES

MARTE

NUVOLATO

PIETRE RARE

TITANO

AGORÀ

ARDESIA

NATURAL SLATE

PIETRE RUNICHE

TIBURTINO

rosa norvegia



rosa portogallo



rosa brasil

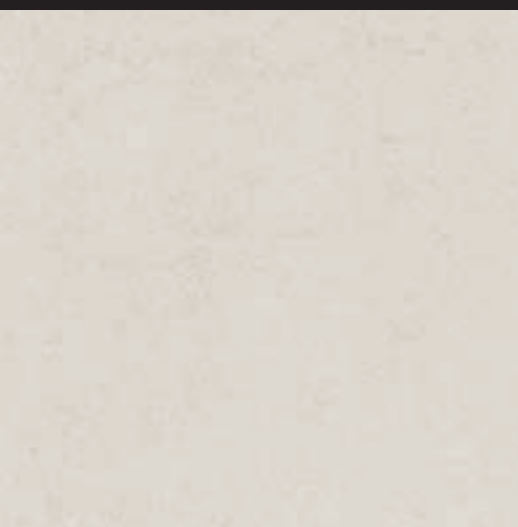

thassos



grigio egeo

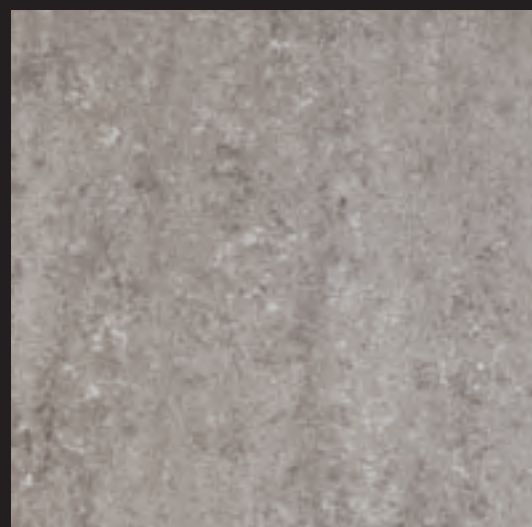

raggio di luna

rosso soraya

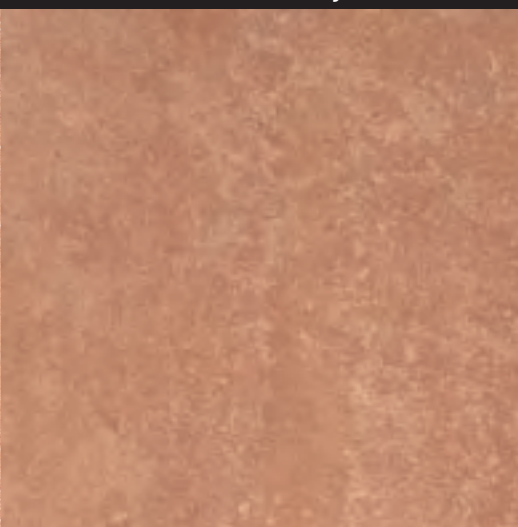

madras pink



emperador

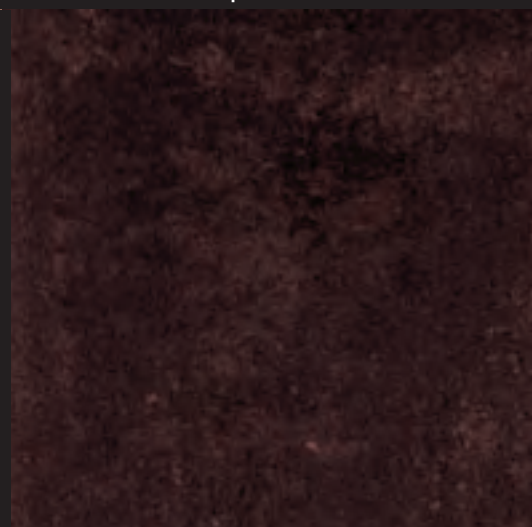

grigio marostica



grigio maggia

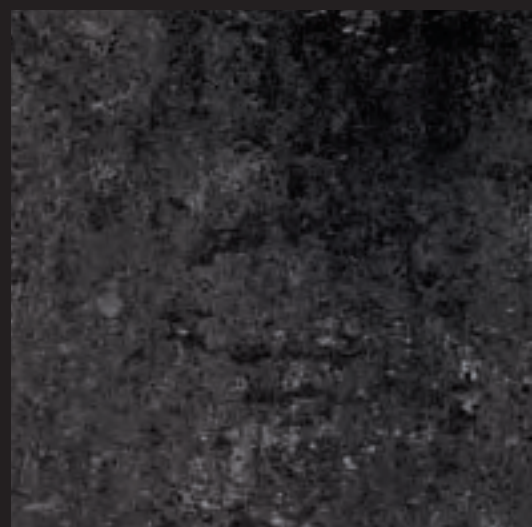

nero acapulco

botticino



palissandro

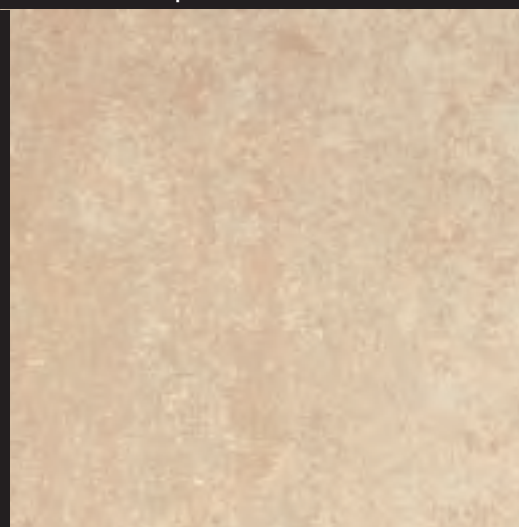

crema marfil

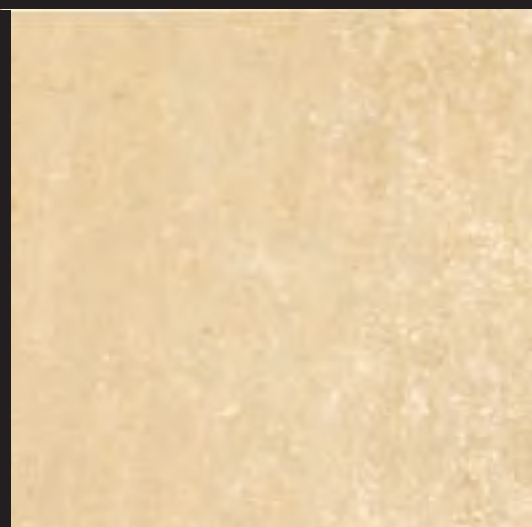

azul bahia



azul macauba



verde guatemala

giallo reale



bronzetto



ramora brown



grigio egeo
emperador
cm 30x60, 60x60



grigio maglia cm 30x60



granitogres

nero acapulco cm 40x40

MARMOGRES

MARTE

NUVOLATO

PIETRE RARE

TITANO

AGORÀ

ARDESIA

NATURAL SLATE

PIETRE RUNICHE

TIBURTINO



grigio egeo, grigio marostica
grigio maggia, giallo reale
rosso soraya
naturale matt, levigato polished, lappato
cm 30x60

Battiscopa Bullnose
Plinthe à bord arrondi Stehsockel
cm 9x30 3½"x12"
cm 9x40 3½"x16"
cm 9x60 3½"x24"

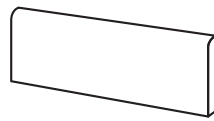

Gradino Step tread
Nez de marche Stufenplatte
cm 30x30 12"x12"
cm 30x60 12"x24"

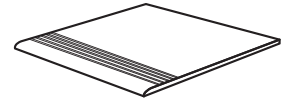

Gradone toro con bordo antiscivolo
Gradone toro with non-slip edge
Gradone toro avec nez antidérapant
Gradone toro mit rutschsicherer Kante
cm 60x33 24"x13"

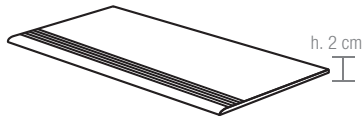

*Zoccolo a raccordo a becco civetta
Cove base with rounded edge
Plinthe à gorge bord arrondi
Hohlkehlsocbel mit abgerundeter Kante
cm 15x30 6"x12"

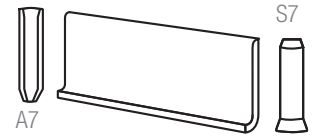

Gradone toro
cm 60x33 24"x13"
cm 120x33 48"x13"

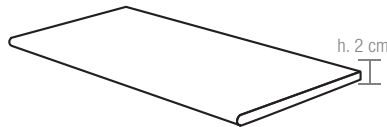

Angolare toro
cm 60x33 24"x13"
cm 120x33 48"x13"

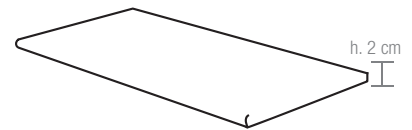

Scalino
cm 40x33 16"x13"

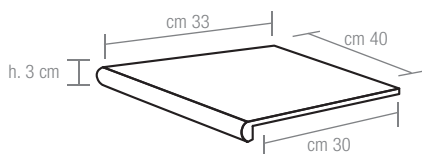

Scalino angolare
cm 40x33 16"x13"

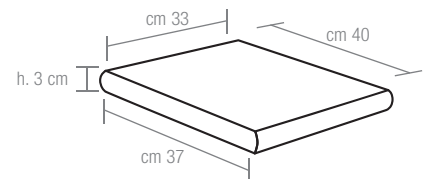

Gradone
cm 30x33 24"x13"
cm 60x33 48"x13"

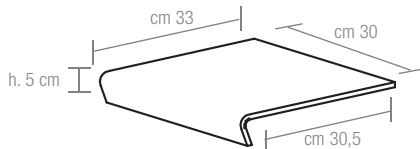

Gradone angolare
cm 30x33 24"x13"
cm 60x33 48"x13"

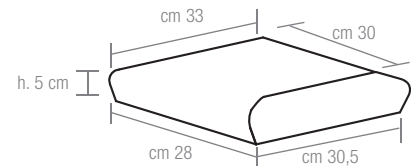

Battiscala DX**
cm 39x27 15½"x10¾"

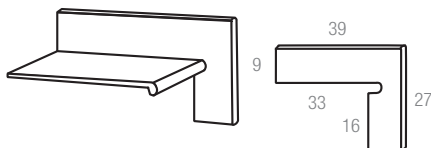

Battiscala SX**
cm 39x27 15½"x10¾"



*non rettificato **not rectified** non rectifié **nicht rektifiziert**
produzione corrente solo nei colori **currently produced only in the following colours**
productions courantes seulement dans les couleurs **aktuelle Produktion nur in den Farben:**

botticino, bronzetto, grigio egeo, nero acapulco, palissandro, raggio di luna

altri colori a richiesta **other colours available on request** autres couleurs sur demande **weitere Farben auf Wunsch**

Solo su ordinazione. **Attenzione! Specificare nell'ordine se il battiscala deve essere abbinato a scalino (h. 3 cm) o a gradone toro (h. 2 cm)
Only on request. **Important!** The order must specify whether the battiscala must match a scalino (3 cm h.) or a gradone toro (2 cm h.).

Seulement sur commande. **Attention!** Spécifier dans la commande si le battiscala doit être assorti au scalino (h. 3cm) ou au gradone toro (h. 2 cm)

Nur auf Bestellung. **Achtung!** Beim Auftrag ist es zu vermerken, ob die Stufensockel (battiscala) zusammen mit dem scalino (3 cm hoch) bzw. dem gradone toro (2 cm hoch) zu kombinieren sind

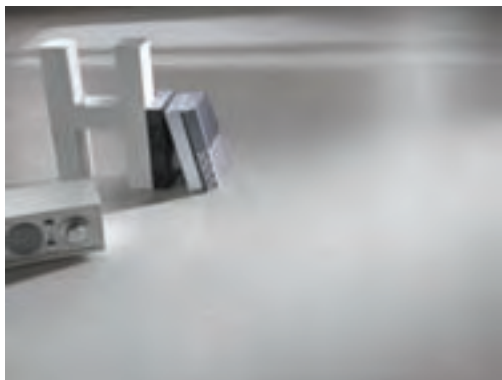

thassos
cm 15x120, 20x120

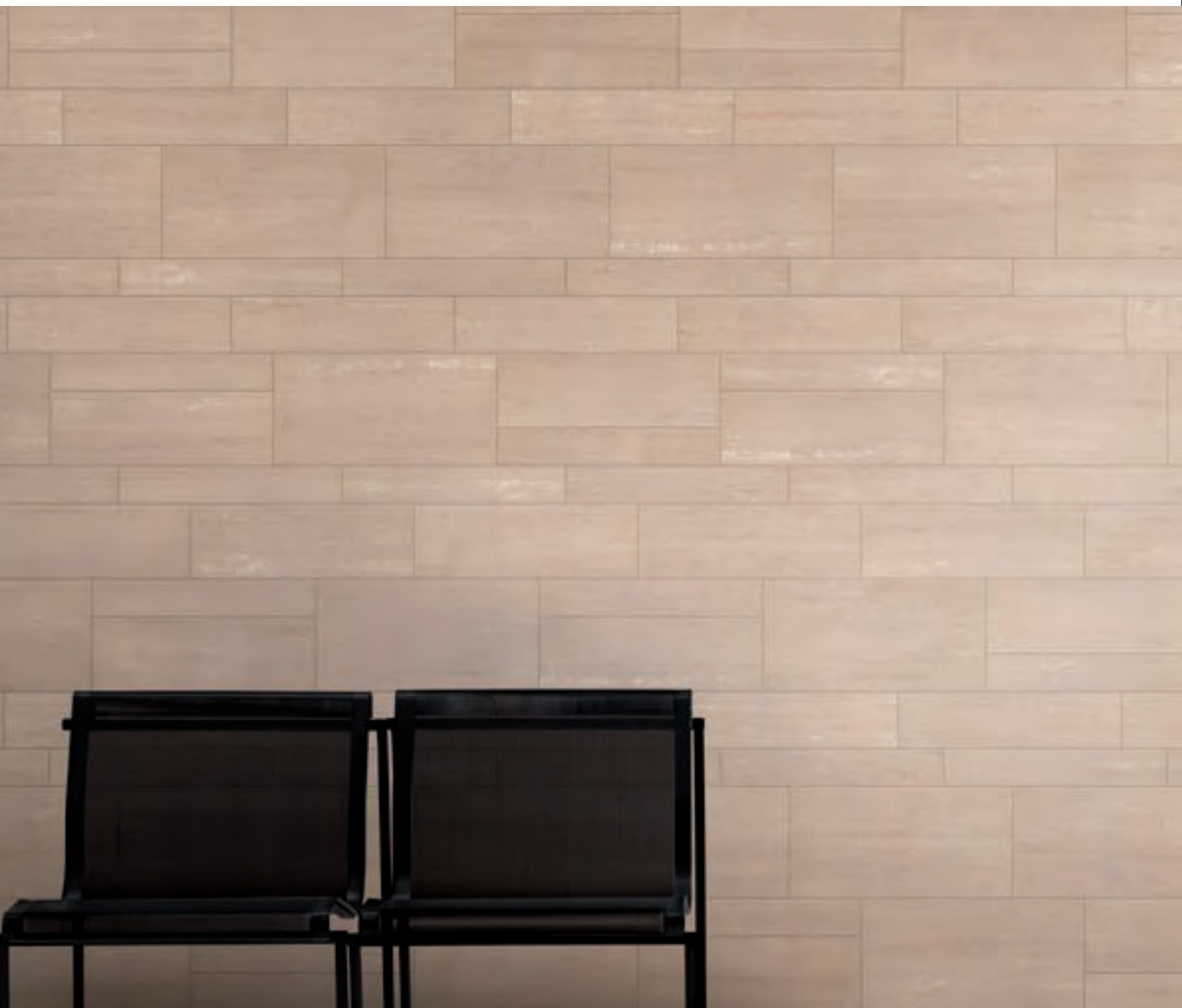

bronzetto cm 10x60, 15x60, 20x60, 30x60



emperador satinato satin finished cm 30x60

levigata
polished
polie
poliert

honed

satinata
satin finished
satiné
satiniert

naturale
matt
naturel
matt
R9 A

bocciardata
bocciardata
bouchardé
gehämmert
R11 A+B

MOSAICO*



tessera
cm 2,5x2,5 1"x1"

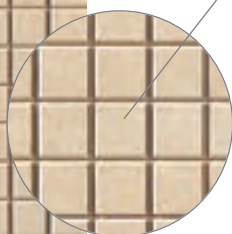

cm 30x30 12"x12"

superficie naturale e levigata
matt and polished surface
surface naturelle et polie
matte und polierte Oberfläche

MOSAICO*

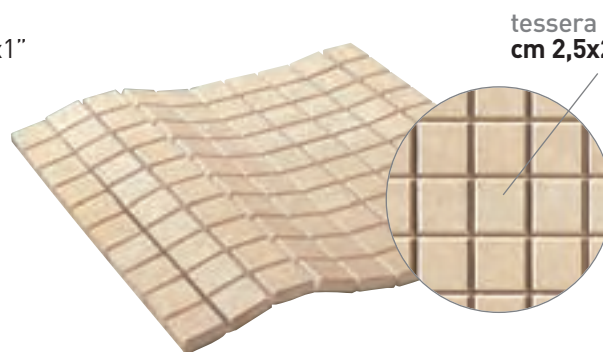

tessera
cm 2,5x2,5 1"x1"

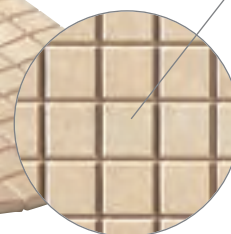

cm 30x30 12"x12"

su rete on net sur trame auf Netz

solo superficie levigata
polished surface only
seulement surface polie
nur in polierter Oberfläche

LISTELLI*



listello
cm 2,5x30 1"x12"



cm 30x30 12"x12"

su rete on net sur trame auf Netz

solo superficie levigata
polished surface only
seulement surface polie
nur in polierter Oberfläche

*Disponibile in tutti i colori della serie
Available in all the colours of the series
Disponibile dans tous les couleurs de la série
Verfügbar in allen Farben

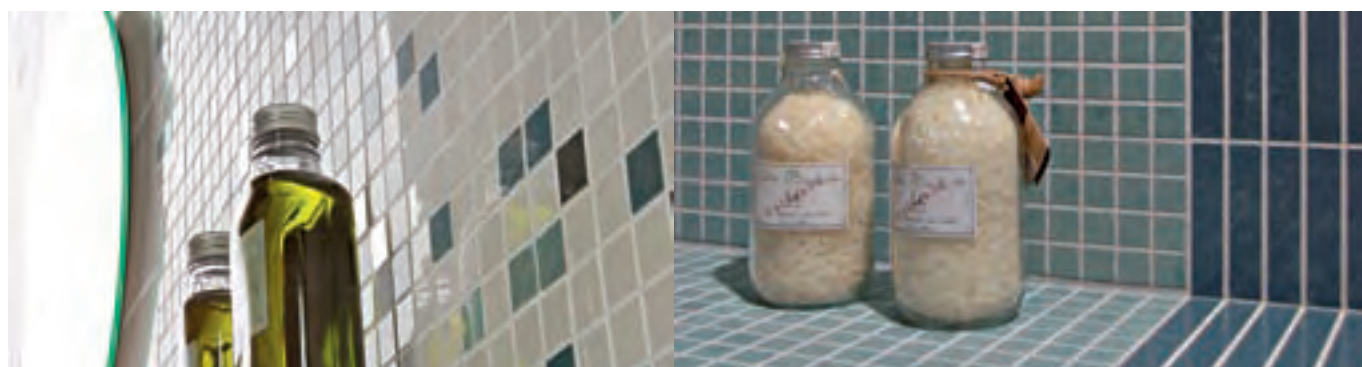

mosaico mix B cm 30x30

mosaico azul macauba cm 30x30
listelli azul bahia cm 30x30

DECORO A*

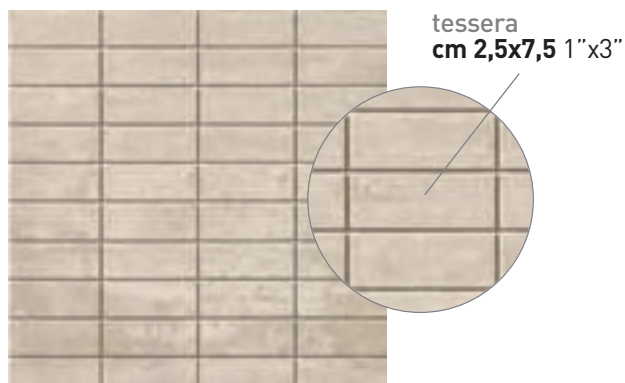

tessera
cm 2,5x7,5 1"x3"

cm 30x30 12"x12"

DECORO B*

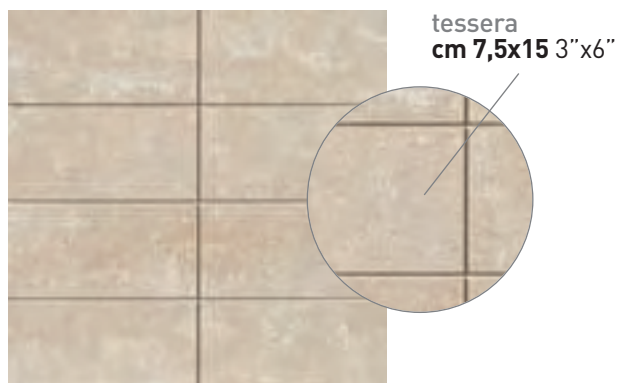

tessera
cm 7,5x15 3"x6"

cm 30x30 12"x12"

DECORO C*



listelli
cm 1,5x60 1/2"x24"

cm 30x60 12"x24"

DECORO D*

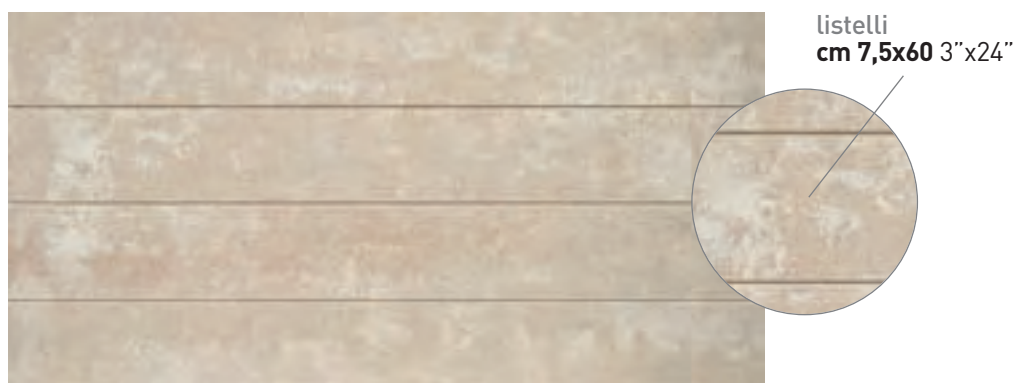

listelli
cm 7,5x60 3"x24"

cm 30x60 12"x12"

*disponibile in tutti i colori della serie, solo nella versione naturale
available in all the colours of the series, only in matt version
disponible dans toutes les couleurs de la série, seulement dans la version naturelle
verfügbar in allen Farben, nur in matt

per mettere in risalto la trama del decoro si consiglia l'utilizzo di fughe colorate in contrasto con il colore della piastrella
we recommend use of coloured grouting that contrasts with the colour of the tiles to emphasize the patterning
pour mettre en valeur la trame du décor, nous conseillons d'utiliser des joints colorés en contraste avec la couleur du carreau
zur hervorhebung des verzierungsmusters empfiehlt es sich, von der fliesenfarbe abweichende farbige fugen zu verwenden

MOSAICO TEXTURE*

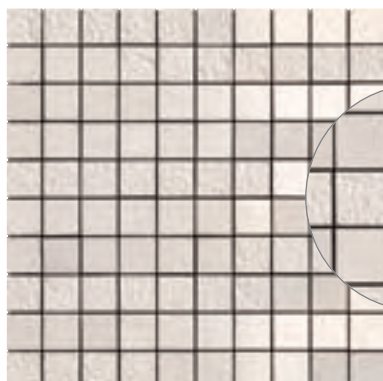

tessera
cm 2,5x2,5 1"x1"

*disponibile in tutti
i colori della serie
available in all
the colours of the series
disponible dans toutes
les couleurs de la série
verfügbar in allen Farben

cm 30x30 12"x12"

su rete on net sur trame auf Netz

naturale, levigato, bocciardato

matt, polished, bocciardato

naturel, poli, bouchardé

matt, poliert, gehämmert

mosaico texture thassos cm 30x30

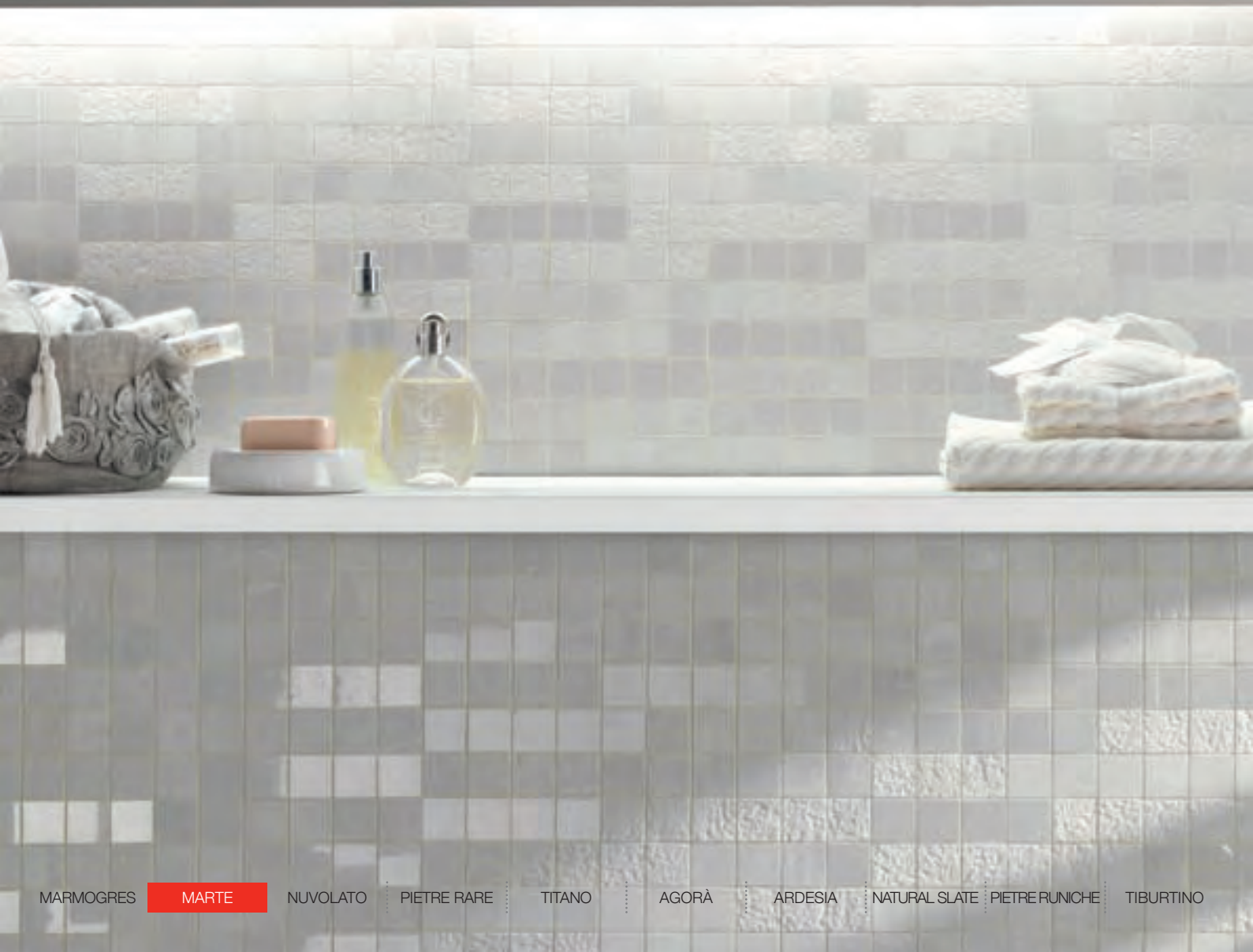

LISTELLI TEXTURE*

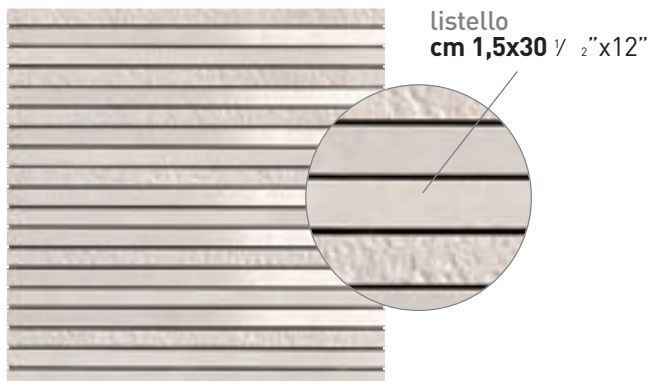

cm 30x30 12"x12"

su rete on net sur trame auf Netz

naturale, levigato, bocciardato

matt, polished, bocciardato

naturel, poli, bouchardé

matt, poliert, gehämmert

*disponibile in tutti i colori della serie

available in all the colours of the series

disponible dans toutes les couleurs de la série

verfügbar in allen Farben



listelli texture thassos cm 30x30

LISTELLO STRASS THASSOS



cm 4x60 1 1/2"x24"

LISTELLO STRASS NERO ACAPULCO



cm 4x60 1 1/2"x24"

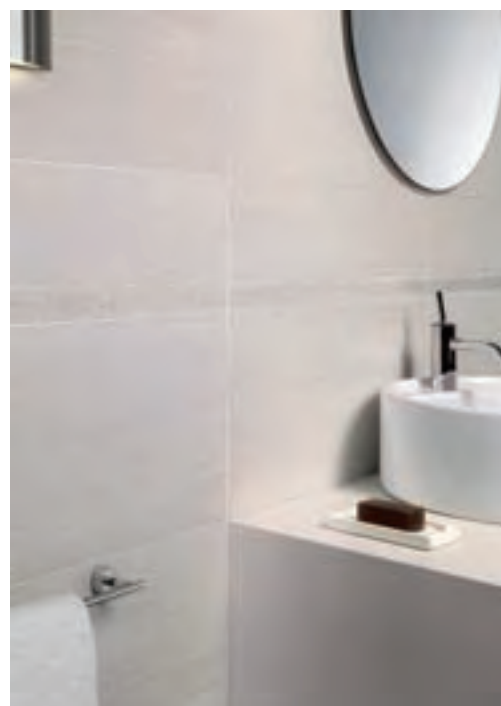

thassos cm 15x60, 30x60
listello strass thassos cm 4x60

granitogres



thassos cm 60x120
listelli texture thassos cm 30x30

MARMOGRES

MARTE

NUVOLATO

PIETRE RARE

TITANO

AGORÀ

ARDESIA

NATURAL SLATE

PIETRE RUNICHE

TIBURTINO

botticino cm 30x30
azul macauba cm 30x60
mosaico azul bahia cm 30x30
mosaico azul macauba cm 30x30
levigato polished

44 45



MOSAICO MIX A

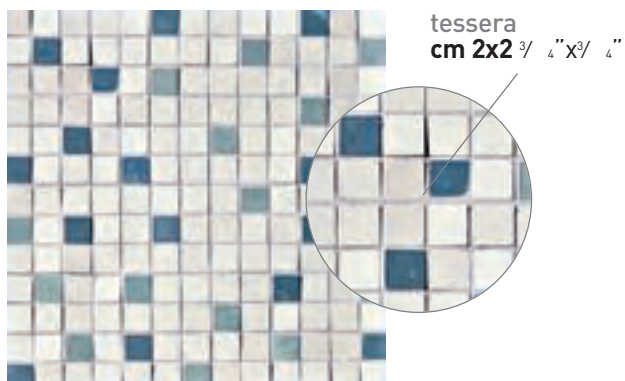

cm 30x30 12"x12"

Bianco Assoluto,
Azul Bahia, Azul Macauba

MOSAICO MIX B

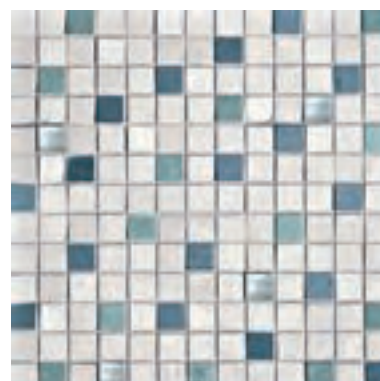

cm 30x30 12"x12"

Bianco Assoluto, Azul
Bahia, Azul Macauba,

MOSAICO MIX C



cm 30x30 12"x12"

Grigio Egeo, Grigio Maggia,
Raggio di Luna

MOSAICO MIX D



cm 30x30 12"x12"

Grigio Egeo, Grigio Maggia,
Raggio di Luna, Acciaio

MOSAICO MIX E

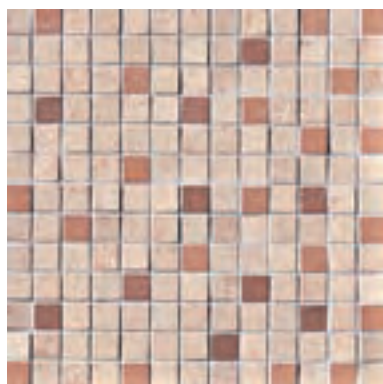

cm 30x30 12"x12"

Rosa Portogallo,
Rosso Soraya, Madras Pink

MOSAICO MIX F

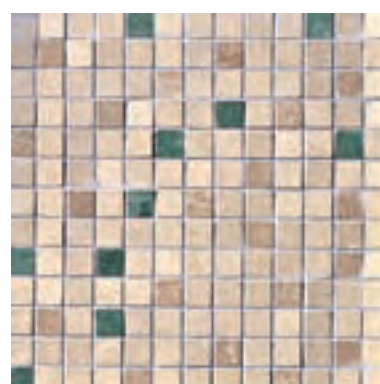

cm 30x30 12"x12"

Botticino, Bronzetto,
Palissandro, Verde Guatemala

**FASCIA MUSIVA
BIANCO ASSOLUTO**



cm 8x30 3/4" x 12"

Bianco Assoluto,
Azul Macauba

**FASCIA MUSIVA
BOTTICINO**



cm 8x30 3/4" x 12"

Botticino, Bronzetto

**FASCIA MUSIVA
GRIGIO EGEO**



cm 8x30 3/4" x 12"

Grigio Egeo, Grigio Maggia

**FASCIA MUSIVA
ROSA PORTOGALLO**



cm 8x30 3/4" x 12"

Rosso Soraya,
Rosa Portogallo

azul macauba
cm 30x60
levigato polished
bianco assoluto
cm 15x60
levigato polished
mosaico mix B
cm 30x30
fascia musiva
bianco assoluto
cm 8 x 30



FASCIA ALLUMINIO*



cm 4x30 1/2"x12"

*disponibile nei colori
available in the colours
disponible dans les couleurs
verfügbar in den folgenden Farben:
**azul bahia, giallo reale,
madras pink, nero acapulco,**

TERMINALE ALLUMINIO



cm 1x30 3/8"x12"

ANGOLO TERMINALE ALLUMINIO



cm 1x1 3/8"x3/8"

MATITA ALLUMINIO



cm 1,2x30 1/2"x12"

TOZZETTO ALLUMINIO



cm 1,5x1,5 1/2"x1/2"

MATITA cm 1x30 3/8"x12"



ramora brown



verde guatemala



azul bahia



azul macauba



thassos



grigio egeo



raggio di luna



grigio marostica



grigio maggio



nero acapulco



bronzetto



giallo reale



crema marfil



palissandro



botticino



rosa norvegia



rosa portogallo



rosa brasil



rosso soraya



madras pink



emperador

MOSAICO 3D*

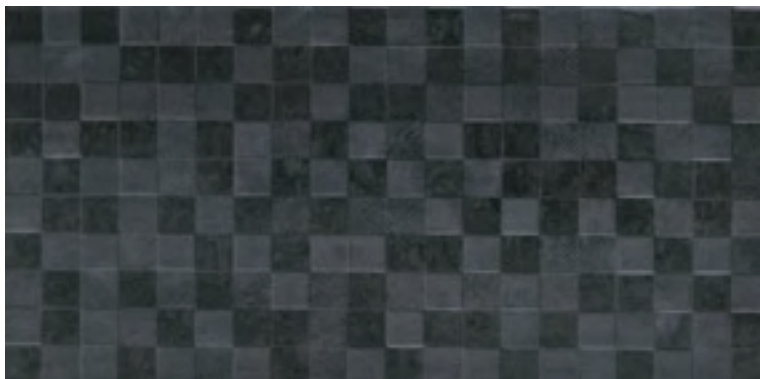

cm 30x60 12"x24"

*disponibile nei colori
thassos, nero acapulco
 superficie naturale e levigata
 available in the colours
thassos, nero acapulco
 matt and polished surface
 disponible dans les couleurs
thassos, nero acapulco
 surface naturelle et polie
 verfügbar in den folgenden Farben:
thassos, nero acapulco
 matte und polierte Oberfläche

MURETTO 3D**

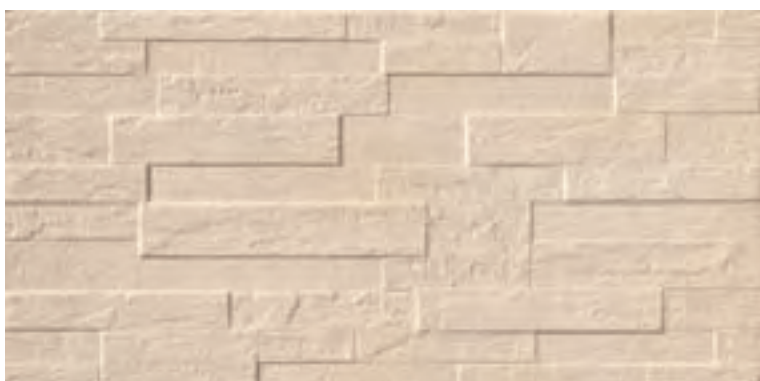

cm 30x60 12"x24"

**disponibile nel colore
 available in the colour
 disponible dans la couleur
 verfügbar in der Farbe:
palissandro naturale

Mosaico 3D e **Muretto 3D** sono effetti ottenuti per pressatura di lastre di 30 x 60 cm
Mosaico 3D and **Muretto 3D** are actually obtained by pressing 30 x 60 cm plates
Mosaico 3D et **Muretto 3D** ce sont des effets obtenus par pressage de dalles de 30 x 60 cm
Mosaico 3D und **Muretto 3D** sind erzeugten Effekten durch Pressen der 30 x 60 Fliesen

muretto 3D palissandro cm 30x60

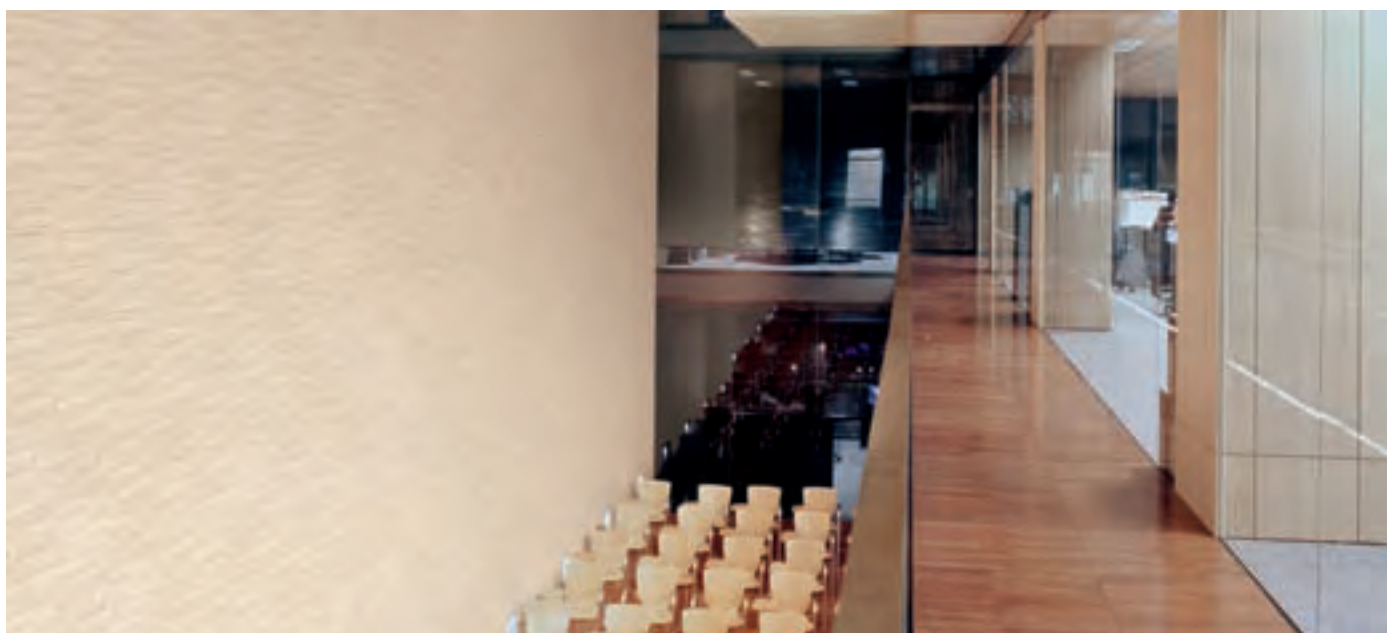

thassos
cm 30x60
levigato polished
mosaico 3D
nero acapulco
cm 30x60
levigato polished

DECORO GOCCE*



cm 30x60 12"x24"

FASCIA GOCCE*



cm 3x60 1 1/8"x24"

MATITA ACCIAIO



BACCHETTA ALLUMINIO



cm 0,3x60 1/4"x24"

*disponibile nei colori
available in the colours
disponible dans les couleurs

verfügbar in den folgenden Farben:

azul bahia, emperador, nero acapulco, ramora brown

(superficie naturale, matt surface, surface naturelle, matte Oberfläche)

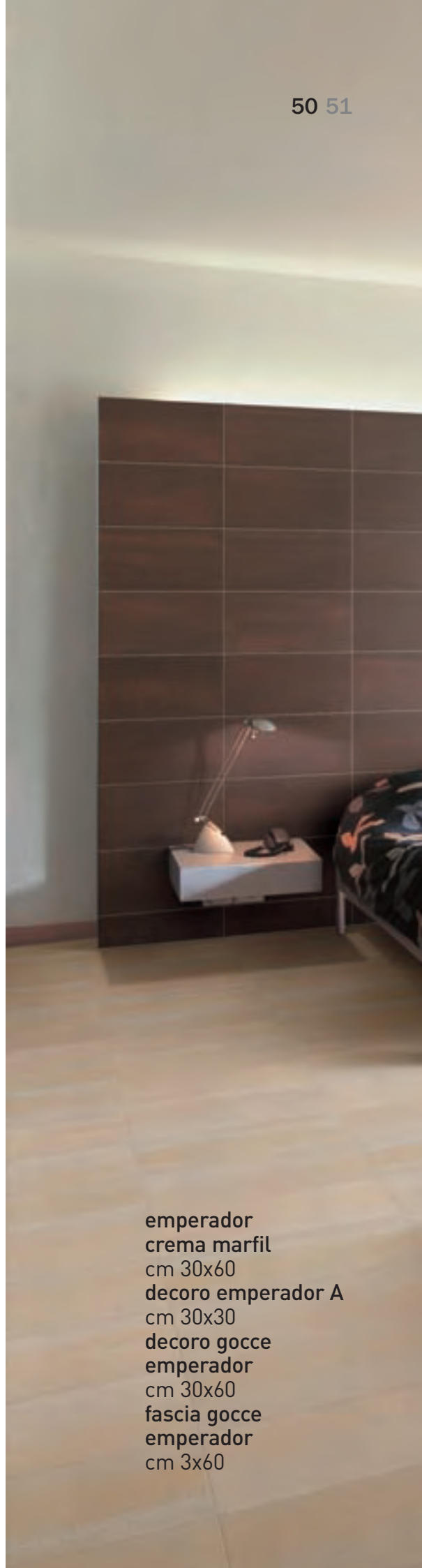

emperador
crema marfil
cm 30x60
decoro emperador A
cm 30x30
decoro gocce
emperador
cm 30x60
fascia gocce
emperador
cm 3x60





grigio egeo
nero acapulco
cm 30x60
levigato polished
fascia platino
nero acapulco
cm 8x30

FASCIA PLATINO



cm 8x30 3/4"x12"

cm 8x30 3/4"x12"

disponibile nei colori
available in the colours
disponible dans les couleurs
verfügbar in den folgenden Farben:
**azul bahia, bronzetto, madras pink,
nero acapulco, verde guatemala**

i due motivi della "Fascia Platino" sono forniti miscelati in scatole da 10 pezzi
the two designs of the "Fascia Platino" are sold in mixed boxes of 10 pieces
les deux motifs de la "Frise Platino" sont vendus mélangés en boîtes de 10 pièces
die beiden Motive von "Fascia Platino" werden gemischt in Kartons zu je 10 Stück verkauft

piastrella tagliata a idrogetto per inserimento decoro
hydrojet cut tile for the insertion of decorative pieces
carreau coupé par hydrojet pour l'insertion de décorations
mit Wasserstrahl geschnittene Fliese zum einlegen von Dekoren

FASCIA RINASCIMENTO A

ANGOLO RINASCIMENTO A

FASCIA RINASCIMENTO B

ANGOLO RINASCIMENTO B



cm 15x30

cm 15x15

cm 15x30

cm 15x15

Rosa Norvegia

disponibile nei colori available in the colours
disponible dans les couleurs
verfügbar in den folgenden Farben:

botticino (botticino, verde guatemala);
grigio egeo (grigio egeo, azul bahia);
palissandro (palissandro, madras pink);
rosa norvegia (rosa norvegia, nero acapulco, rosa brasilie);

Rosa Norvegia

disponibile nei colori available in the colours
disponible dans les couleurs
verfügbar in den folgenden Farben:

botticino (botticino, verde guatemala, bronzetto);
grigio egeo (grigio egeo, azul bahia, raggio di luna);
palissandro (palissandro, madras pink, rosso soraya);
rosa norvegia (rosa norvegia, nero acapulco, rosa brasilie);

FASCIA FLOREALE A



cm 15x30

FASCIA FLOREALE B



cm 15x30

ANGOLO FLOREALE

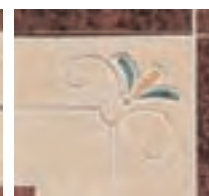

cm 15x15

Palissandro

disponibile nei colori available in the colours disponible dans les couleurs verfügbar in den folgenden Farben:

botticino (botticino, madras pink); **grigio egeo** (grigio egeo, nero acapulco);
palissandro (palissandro, madras pink); **rosa portogallo** (rosa portogallo, madras pink)

Palissandro

serie NUVOLATO

COLORI COLOURS COULEURS FARBEN



beige

rosa

grigio

TABELLA RIASSUNTIVA FORMATI-SUPERFICI-SPESSORI STANDARD
 TABLE SUMMARISING STANDARD SIZES-SURFACES-THICKNESSES
 TABLEAU RECAPITULATIF DES FORMATS-SURFACES-EPAISSEURS STANDARD
 ZUSAMMENFASSENDE TABELLE STANDARD FORMATE-OBERFLÄCHEN-STÄRKEN

Formati Sizes Formats Formate

cm 40x40 - 16"x16"

Superfici Surfaces Surfaces Oberflächen



Spessori Thicknesses Epaisseurs Stärken

mm 9

● Levigato Polished Poli Poliert

PEZZI SPECIALI TRIMS ACCESSOIRES FORMSTÜCKE

Battiscopa Bullnose
 Plinthe à bord arrondi Stehsockel
cm 9x40 3½"x16"

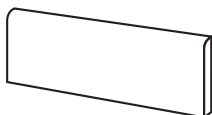

Gradino Step tread
 Nez de marche Stufenplatte
cm 40x40 16"x16"

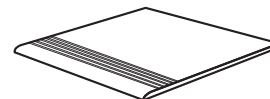

granitogres

serie PIETRE RARE

civiale brown
cm 30x60
bocciardato



MARMOGRES

MARTE

NUVOLATO

PIETRE RARE

TITANO

AGORÀ

ARDESIA

NATURAL SLATE

PIETRE RUNICHE

TIBURTINO

monviso



serena



varana

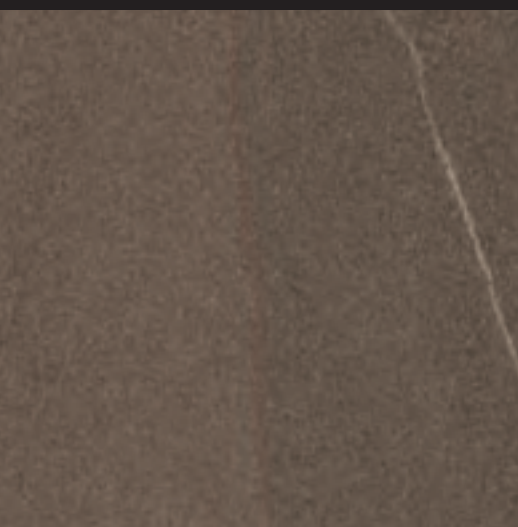

cividale brown

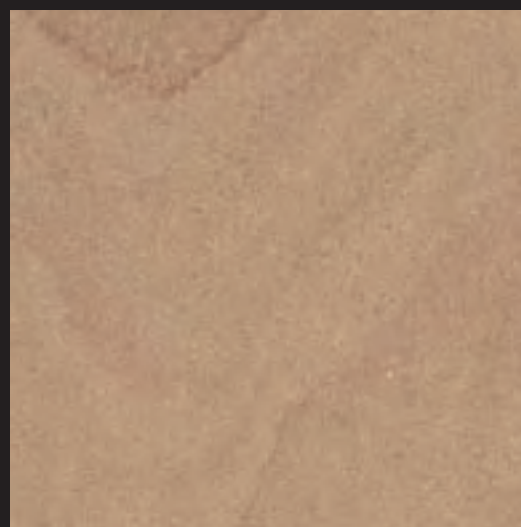

gascogne

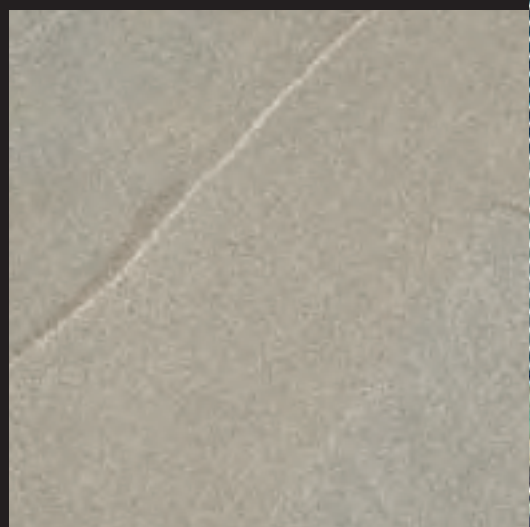

cividale grey

monviso
cm 60x60
bocciardato

granitogres



MARMOGRES

MARTE

NUVOLATO

PIETRE RARE

TITANO

AGORÀ





ARDESIA

NATURAL SLATE

PIETRE RUNICHE

TIBURTINO

TABELLA RIASSUNTIVA FORMATI-SUPERFICI-SPESSORI STANDARD
 TABLE SUMMARISING STANDARD SIZES-SURFACES-THICKNESSES
 TABLEAU RECAPITULATIF DES FORMATS-SURFACES-EPAISSEURS STANDARD
 ZUSAMMENFASSENDE TABELLE STANDARD FORMATE-OBERFLÄCHEN-STÄRKEN

					
Formati Sizes Formats Formate	cm 30x30 12"x12"	cm 40x40 16"x16"	cm 15x60 6"x24"	cm 30x60 12"x24"	cm 60x60 24"x24"
Civiale Brown	● ● ● ●		● ● ● ●	● ● ● ●	● ● ● ●
Civiale Grey	● ● ● ●		● ● ● ●	● ● ● ●	● ● ● ●
Gascogne	● ● ● ●		● ● ● ●	● ● ● ●	● ● ● ●
Monviso	● ● ● ●		● ● ● ●	● ● ● ●	● ● ● ●
Serena	●* ● ●	●* ● ●	●* ● ●	●* ● ●	●* ● ●
Varana	●* ● ●	●* ● ●	●* ● ●	●* ● ●	●* ● ●
Spessori** Thicknesses** Epaisseurs** Stärken**	mm 9,5	mm 9,5	mm 9,5	mm 9,5	mm 10,5

- Naturale Matt Naturelle Natur R9 ●* Naturale Matt Naturelle Natur R9 A
- Levigato Polished Polie Poliert
- Satinato Satin Finished Satiné Satiniert
- Bocciardato R12 A+B+C

**Spessore su superficie naturale e satinata Thickness on matt and satinated surface
 Épaisseur sur surface mat et satinée Stärke der Fliesen mit Matt - satinierten Oberfläche

Le piastrelle della serie Pietre Rare sono fornite te in un unico calibro

The tiles in the Pietre Rare series come in a single caliber, rectified version

Les carreaux de la série Pietre Rare sont fournis rectifiés en un unique calibre

Die Fliesen der Serie Pietre Rare werden in einem einzigen Werkmass massgeschliffen geliefert

serena
cm 30x60



Battiscopa Bullnose
Plinthe à bord arrondi Stehsockel

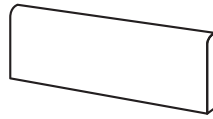

cm 9x30 3/2"x12" cm 9x40 3/2"x16" cm 9x60 3/2"x24"

Cividale Brown	●	●
Cividale Grey	●	●
Gascogne	●	●
Monviso	●	●
Serena	●	●
Varana	●	●

Gradino Step tread
Nez de marche Stufenplatte

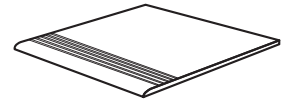

cm 30x30 12"x12" cm 40x40 16"x16" cm 30x60 12"x24"

Cividale Brown	●	●
Cividale Grey	●	●
Gascogne	●	●
Monviso	●	●
Serena	●	●
Varana	●	●

Tozzetto Insert
Cabochon Einleger

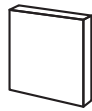

cm 9x9 3/2"x3/2"

Cividale Brown	●
Cividale Grey	●
Gascogne	●
Monviso	●
Serena	●
Varana	●

Listello Listel
Listel Zeierleiste

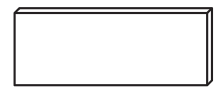

cm 9x30 3/2"x12" cm 9x40 3/2"x16"

Cividale Brown	●	●
Cividale Grey	●	●
Gascogne	●	●
Monviso	●	●
Serena	●	●
Varana	●	●

Gradone

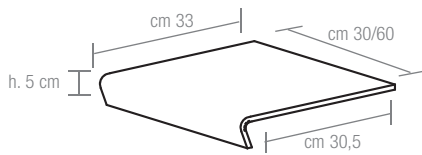

cm 30x33 12"x13" cm 60x33 24"x16"

Cividale Brown	●	●
Cividale Grey	●	●
Gascogne	●	●
Monviso	●	●
Serena	●	●
Varana	●	●

Gradone angolare

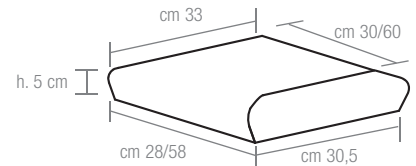

cm 30x33 12"x13" cm 60x33 24"x16"

Cividale Brown	●	●
Cividale Grey	●	●
Gascogne	●	●
Monviso	●	●
Serena	●	●
Varana	●	●

Terminale

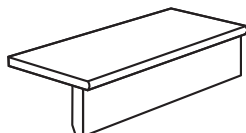

cm 15x30x5 6"x12"x2"

Cividale Brown	●
Cividale Grey	●
Gascogne	●
Monviso	●
Serena	●
Varana	●



gascogne
levigato polished
cm 60x60

levigata
polished
polie
poliert

bocciardata
bocciardata
bouchardé
gehämmert
R12 A+B+C

satinata
satin finished
satiné
satiniert

naturale
matt
naturel
matt
R9

granitogres

serie TITANO

caen
honed
cm 45x45



MARMOGRES

MARTE

NUVOLATO

PIETRE RARE

TITANO

AGORÀ

ARDESIA

NATURAL SLATE

PIETRE RUNICHE

TIBURTINO

matraia



cardoso



grigio ash

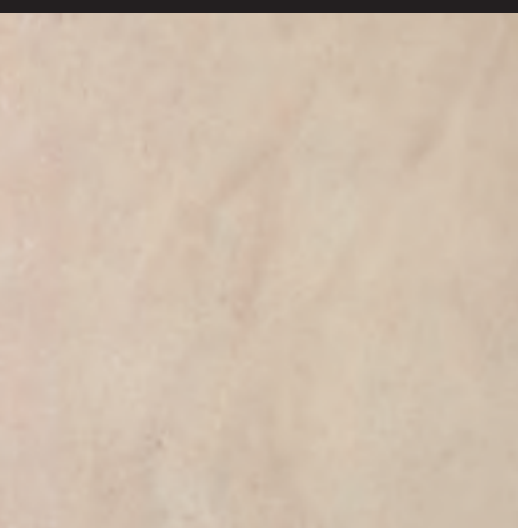
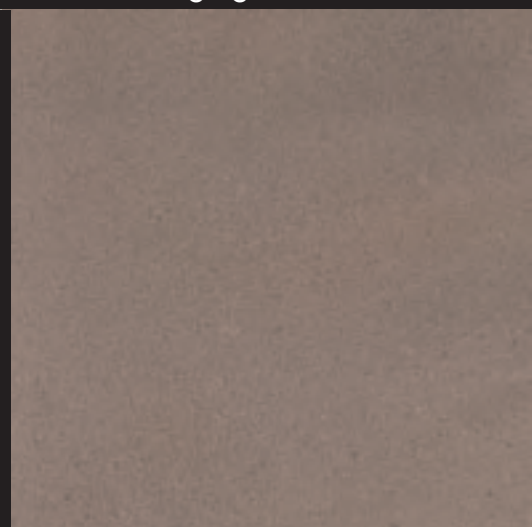

caen



champagne

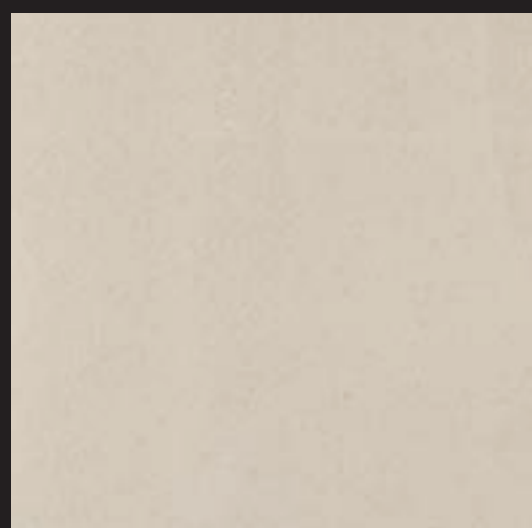

chambrod



Media stonalizzazione
Medium mixed shading
Moyennement dénuancé
Mittleres Farbspiel

buxy



champagne
levigato polished
cm 60x60

TABELLA RIASSUNTIVA FORMATI-SUPERFICI-SPESSORI STANDARD
 TABLE SUMMARISING STANDARD SIZES-SURFACES-THICKNESSES
 TABLEAU RECAPITULATIF DES FORMATS-SURFACES-EPAISSEURS STANDARD
 ZUSAMMENFASSENDE TABELLE STANDARD FORMATE-OBERFLÄCHEN-STÄRKEN

Formati Sizes Formats Formate	cm 15x45 6"x18"	cm 22,5x45 9"x18"	cm 30x30 12"x12"	cm 30x45 12"x18"	cm 30x60 12"x24"	cm 45x45 18"x18"	cm 60x60 24"x24"
Superfici Surfaces Surfaces Oberflächen	● ● ● ●	● ● ● ●	● ● ● ●	● ● ● ●	● ● ● ●	● ● ● ●	● ● ● ●
Spessori Thicknesses Épaisseurs Stärken	mm 9,5	mm 9,5	mm 9,5	mm 9,5	mm 9,5	mm 9,5	mm 10,5

- Naturale Matt Naturelle Natur R9
- Levigato Polished Polie Poliert
- Bocciardato R11 A+B
- Honed

*Spessore su superficie naturale Thickness on matt surface Épaisseur sur surface mat Stärke der Fliesen mit Mattoberfläche

Per poter uniformare gli spessori, specificare al momento dell'ordine una eventuale posa in opera combinata di formati diversi

Please specify when placing your purchase order whether the various positions have to be employed in a combined pattern, so that we can deliver the same thickness

Afin d'uniformiser les épaisseurs, veuillez préciser au moment de la commande si vous effectuez une pose combinée de formats différentes

Um die Fliesenstärken aneinander anpassen zu können, bitte bei der Bestellung angeben, dass Fliesen mit verschiedenen Formate zusammen verlegt werden sollen

PEZZI SPECIALI TRIMS
 ACCESSOIRES FORMSTÜCKE

Battiscopa Bullnose
 Plinthe à bord arrondi Stehsockel
cm 9x30 3½"x12"
cm 9x45 3½"x18"
cm 9x60 3½"x24"

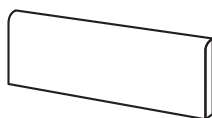

Gradino Step tread
 Nez de marche Stufenplatte
cm 30x30 12"x12"
cm 45x45 18"x18"
cm 30x60 12"x24"

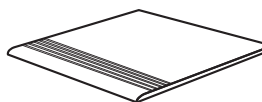

Gradone
cm 60x33 48"x13"

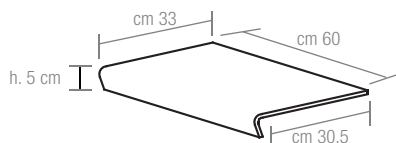

Angolare
cm 60x33 48"x13"

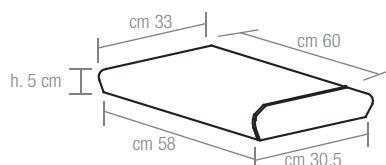

Terminale
cm 15x30x5 6"x12"x2"

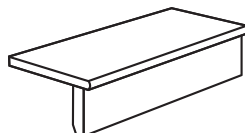

buxy bocciardato cm 30x60

granitogres



grigio ash cm 60x60

MARMOGRES

MARTE

NUVOLATO

PIETRE RARE

TITANO

AGORÀ

ARDESIA

NATURAL SLATE

PIETRE RUNICHE

TIBURTINO



honed

levigata
polished
polie
poliert

naturale
matt
naturel
matt
R9

bocciardata
bocciardata
bouchardé
gehämmert
R11 A+B



matraia honed cm 30x60
fascia matraia C cm 30x60

FASCIA TITANO B*



cm 45x45 18"x18"

ANGOLO TITANO B*

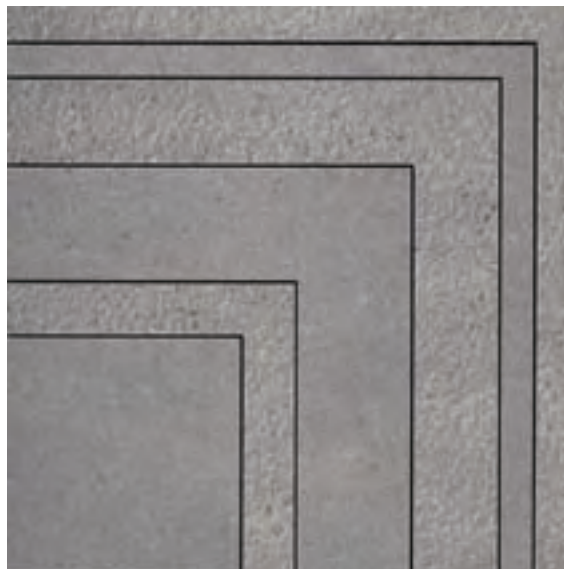

cm 45x45 18"x18"

FASCIA TITANO C*



cm 30x60 12"x24"

*Disponibile in tutti i colori della serie

Available in all the colours of the series

Disponible dans toutes les couleurs de la série

Verfügbar in allen Farben

granitogres rusticato

serie AGORÀ

megalopoli
elatea
cm 15x15
cm 15x30



MARMOGRES

MARTE

NUVOLATO

PIETRE RARE

TITANO

AGORÀ

ARDESIA

NATURAL SLATE

PIETRE RUNICHE

TIBURTINO

micene



sparta



corinto

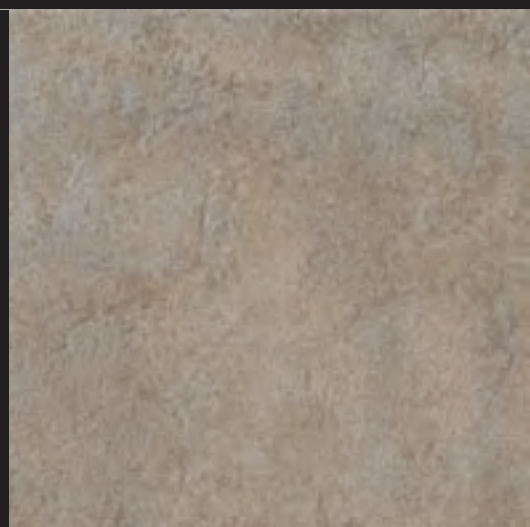

megalopoli



elatea



elide

TABELLA RIASSUNTIVA FORMATI-SUPERFICI-SPESSORI STANDARD
 TABLE SUMMARISING STANDARD SIZES-SURFACES-THICKNESSES
 TABLEAU RECAPITULATIF DES FORMATS-SURFACES-EPAISSEURS STANDARD
 ZUSAMMENFASSENDE TABELLE STANDARD FORMATE-OBERFLÄCHEN-STÄRKEN



granitogres

Formati Sizes Formate Formate	cm 15x15 6"x6" spigoli vivi sharp edges angles droit Scharf-kantig	cm 15x15 6"x6" spigoli arrotondati rounded edges angles arrondis Abgerundete Ecke	cm 15x30 6"x12"	cm 30x30 12"x12"
Superfici Surfaces Surfaces Oberflächen	●	●	●	●
Spessori Thicknesses	mm 8,3	mm 8,3/11,3	mm 8,3	mm 8,3
Epaisseurs Stärken	● Naturale Matt Naturelle Natur R11 A+B			

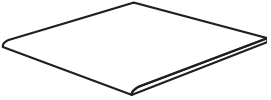
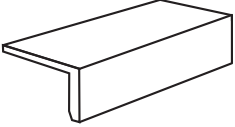
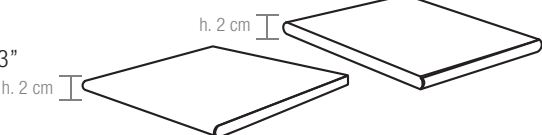
PEZZI SPECIALI TRIMS ACCESSOIRES FORMSTÜCKE

<p>Battiscopa Bullnose Plinthe à bord arrondi Stehsockel cm 9x30 3½"x12"</p> 	<p>Gradino Step tread Nez de marche Stufenplatte cm 30x30 12"x12"</p> 
<p>Terminale Pezzo unico Single piece Une seule pièce Einzelstück cm 15x30x3,5 6"x12"x1½"</p> 	<p>Gradone e gradone angolare cm 25x33 10"x13"</p> 

DECORI DECORS DÉCORS DEKORE

<p>FASCIA RIPOSO MEGALOPOLI*</p>  <p>cm 15x30</p>	<p>FASCIA DECORO MEGALOPOLI*</p>  <p>cm 15x30</p>	<p>ANGOLO MEGALOPOLI*</p>  <p>cm 15x15</p>
--	---	---

*disponibile nelle versioni available in the colours disponible dans les couleurs Verfügbar in den folgenden Farben:
megalopoli (elide, elatea, megalopoli, ardesia verde); **sparta** (corinto, sparta, ardesia verde)

ARDESIA NERO

granitogres rusticato

serie ARDESIA

ardesia grigio
ardesia
bianco
cm 15x15,
15x30, 30x30



ardesia nero



ardesia grigio



ardesia verde

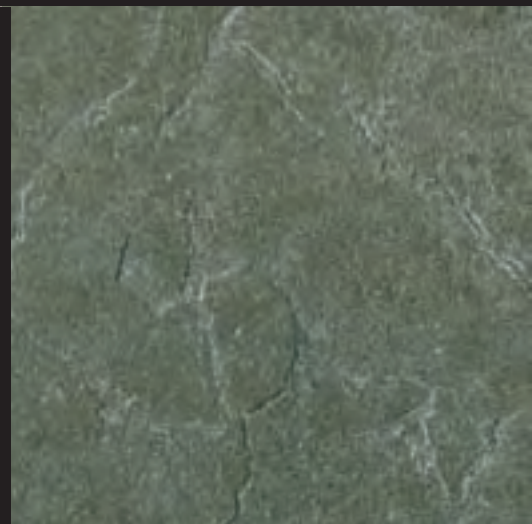

ardesia rosso



ardesia rosa

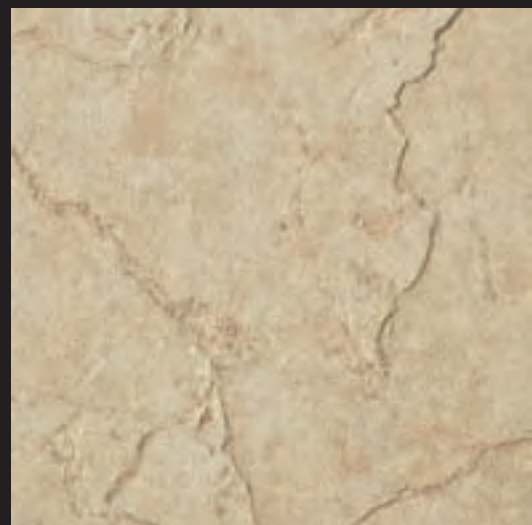

ardesia beige

ardesia blu





ardesia bianco



ardesia bianco
ardesia grigio
ardesia nero
cm 15x15, 15x30, 30x30

TABELLA RIASSUNTIVA FORMATI-SUPERFICI-SPESSORI STANDARD
 TABLE SUMMARISING STANDARD SIZES-SURFACES-THICKNESSES
 TABLEAU RECAPITULATIF DES FORMATS-SURFACES-EPAISSEURS STANDARD
 ZUSAMMENFASSENDE TABELLE STANDARD FORMATE-OBERFLÄCHEN-STÄRKEN

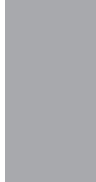
				
Formati Sizes Formats Formate	cm 15x15 6"x6"	cm 15x30 6"x12"	cm 30x30 12"x12"	cm 30x60* 12"x24"
Superfici Surfaces Surfaces Oberflächen	●	●	●	●
Spessori Thicknesses	mm 8,3	mm 8,3	mm 8,3	mm 9,5
Epaisseurs Stärken	● Naturale Matt Naturelle Natur R10 A+B			

PEZZI SPECIALI TRIMS ACCESSOIRES FORMSTÜCKE

Battiscopa Bullnose
 Plinthe à bord arrondi Stehsockel
cm 9x30 3½"x12"



Gradino Step tread
 Nez de marche Stufenplatte
cm 30x30 12"x12"

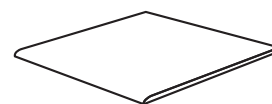

Terminale
 Pezzo unico Single piece
 Une seule pièce Einzelstück
cm 15x30x3,5 6"x12"x1⅜"

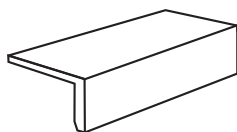

Gradone
 e gradone angolare rusticato
cm 30x30 12"x12"

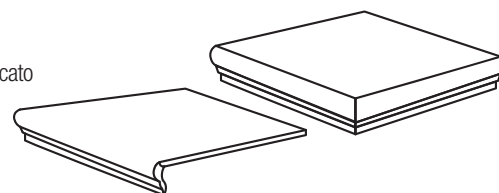

DECORI DECORS DÉCORS DEKORE

FASCIA
 ARDESIA A*



cm 15x30

ANGOLO
 ARDESIA A*



cm 15x15

*disponibile nelle versioni available in the colours disponible dans les couleurs Verfügbar in den folgenden Farben:
A (Rosa, Rosso, Beige); **B** (Grigio, Nero, Bianco); **C** (Grigio, Bianco, Verde)

granitogres **rusticato**

ardesia bianco
cm 15x15, 15x30, 30x30

MARMOGRES

MARTE

NUVOLATO

PIETRE RARE

TITANO

AGORÀ

ARDESIA

NATURAL SLATE

PIETRE Runiche

TIBURTINO

SLATE BLACK

granitogres rusticato

serie NATURAL SLATE

slate black
cm 15x30,
15x45, 30x45

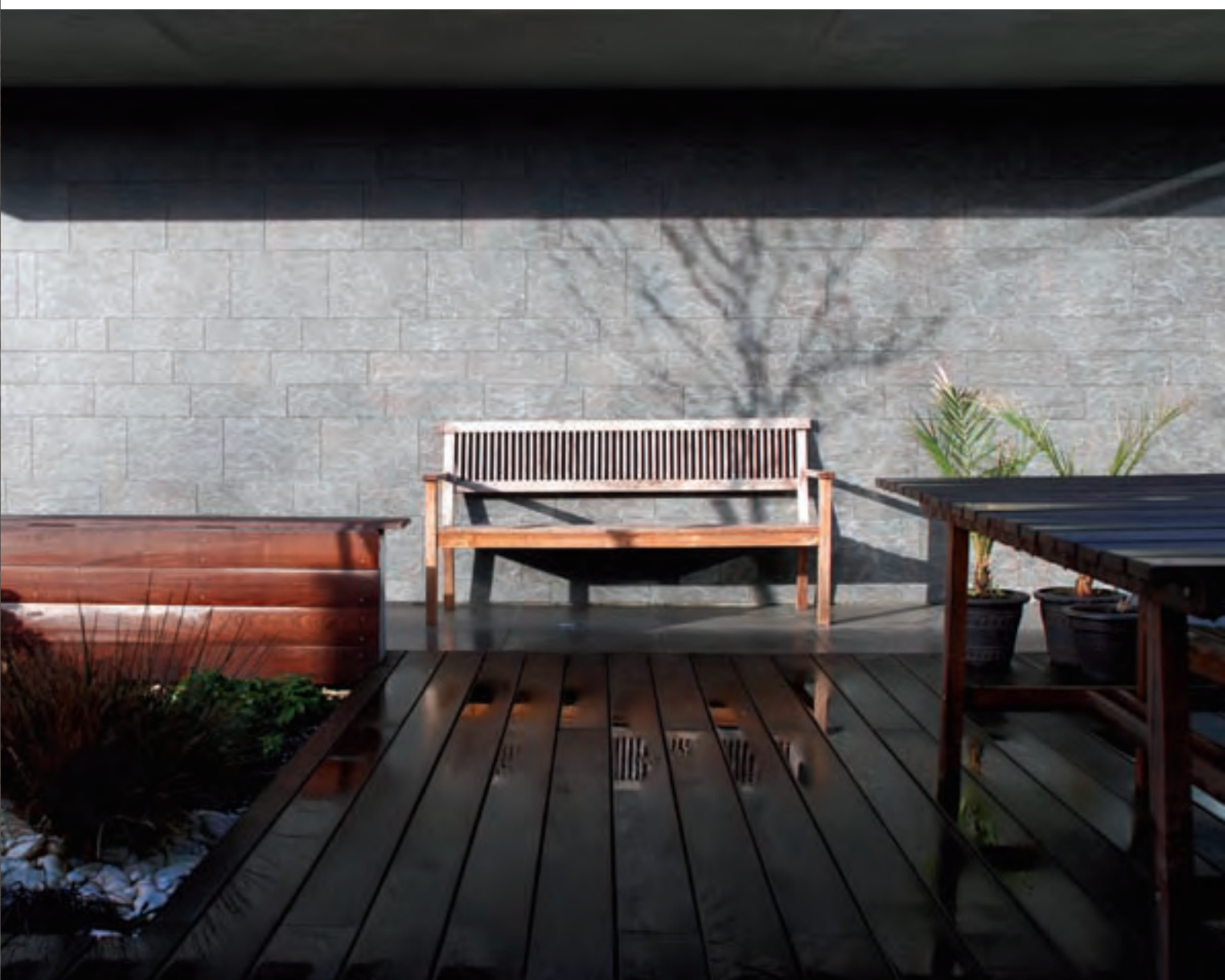

slate black



slate grey



slate red



slate green



slate gold



slate beige

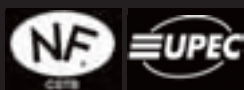

Media stonalizzazione
Medium mixed shading
Moyennement dénuancé
Mittleres Farbspiel

TABELLA RIASSUNTIVA FORMATI-SUPERFICI-SPESSORI STANDARD
 TABLE SUMMARISING STANDARD SIZES-SURFACES-THICKNESSES
 TABLEAU RECAPITULATIF DES FORMATS-SURFACES-EPAISSEURS STANDARD
 ZUSAMMENFASSENDE TABELLE STANDARD FORMATE-OBERFLÄCHEN-STÄRKEN

granitogres

Formati Sizes Formats Formate	cm 15x15 6"x6"	cm 15x30 6"x12"	cm 15x45 6"x18"	cm 30x30 12"x12" non rettificato not rectified	cm 30x30 12"x12"	cm 30x45 12"x18"	cm 45x45 18"x18"
Superfici Surfaces Surfaces Oberflächen	●	●	●	●	●	●	●
Spessori Thicknesses Épaisseurs Stärken	mm 9	mm 9	mm 9	mm 9	mm 9	mm 9	mm 9

● Naturale Matt Naturelle Natur **R10 A+B**

Le piastrelle della serie Natural Slate, sono fornite in spessore 9 mm, rettificate e modulari (fuga 4 mm). È disponibile, nel solo formato 30x30, anche la versione non rettificata. The tiles in the Natural Slate series are 9 mm thick, ground and modular (4 mm joint). The unground version is available only in the 30x30 format. Les carreaux de la série Natural Slate, sont fournis en épaisseur 9 mm, rectifiés et modulaires (joint 4 mm). La version non rectifiée est disponible dans le seul format 30x30. Die Fliesen der Serie Natural Slate werden in der Stärke 9 mm kalibriert und modulär (4 mm Fuge) geliefert. Nur im Format 30x30 ist auch die nicht kalibrierte Ausführung vorgesehen.

PEZZI SPECIALI TRIMS ACCESSOIRES FORMSTÜCKE

Battiscopa Bullnose
Plinthe à bord arrondi Stehsockel
cm 9x30 3½"x12"
cm 9x45 3½"x18"

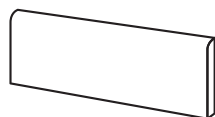

Gradino Step tread
Nez de marche Stufenplatte
cm 30x30 12"x12"

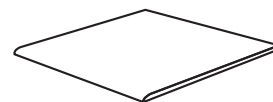

Terminale
Pezzo unico Single piece
Une seule pièce Einzelstück
cm 15x30x3,5 6"x12"x1½"

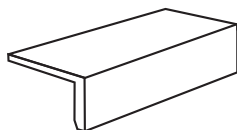

Scalino e scalino angolare
cm 45x33 18"x13"

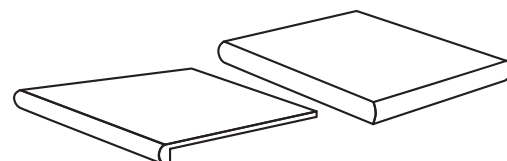

Gradone*
cm 30x33 12"x13"

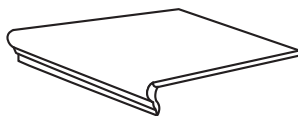

Angolare*
cm 33x33 13"x13"

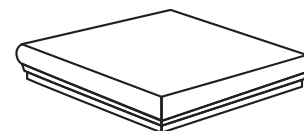

*Solo nei colori Only in the colours Seulement dans les couleurs Nur in den Farben:
Beige, Gold, Grey, Red

DECORI DECORS DÉCORS DEKORE

DECORO NATURAL SLATE



cm 11x11 4⅞" x 4⅞"

I decori sono disponibili in scatole assortite The boxes contain mixed decorations
Les décors sont disponibles par boîtes Die Dekore sind gemischt in Karton verpackt

granitogres rusticato

serie PIETRE RUNICHE

mondo
cm 15x15,
15x30, 30x30,
30x45, 45x45



odino



thor



balder



freyr



mondo



Media stonalizzazione
Medium mixed shading
Moyennement dénuancé
Mittleres Farbspiel

TABELLA RIASSUNTIVA FORMATI-SUPERFICI-SPESSORI STANDARD

granitogres **rusticato**

TABLE SUMMARISING STANDARD SIZES-SURFACES-THICKNESSES

TABLEAU RECAPITULATIF DES FORMATS-SURFACES-EPAISSEURS STANDARD

ZUSAMMENFASSENDE TABELLE STANDARD FORMATE-OBERFLÄCHEN-STÄRKEN

Formati Sizes Formate Formate	cm 15x15 6"x6"	cm 15x30 6"x12"	cm 15x45 6"x18"	cm 30x30 12"x12" non retificato not rectified	cm 30x30 12"x12"	cm 30x45 12"x18"	cm 45x45 18"x18"
Superfici Surfaces Surfaces Oberflächen	●	●	●	●	●	●	●
Spessori Thicknesses Epaisseurs Stärken	mm 9	mm 9	mm 9	mm 9	mm 9	mm 9	mm 9

● Naturale Matt Naturelle Natur **R11 A+B+C**

Le piastrelle della serie Pietre Runiche, sono fornite in spessore 9 mm, rettificate e modulari (fuga 4 mm). È disponibile, nel solo formato 30x30, anche la versione non rettificata.

The tiles in the Pietre Runiche series are 9 mm thick, ground and modular (4 mm joint). The unground version is available only in the 30x30 format.

Les carreaux de la série Pietre Runiche, sont fournis en épaisseur 9 mm, rectifiés et modulaires (joint 4 mm). La version non rectifiée est disponible dans le seul format 30x30.

Die Fliesen der Serie Pietre Runiche werden in der Stärke 9 mm kalibriert und modular (4 mm Fuge) geliefert. Nur im Format 30x30 ist auch die nicht kalibrierte Ausführung vorgesehen.

PEZZI SPECIALI TRIMS ACCESSOIRES FORMSTÜCKE

Battiscopa Bullnose
Plinthe à bord arrondi Stehsockel
cm 9x30 3½"x12"
cm 9x45 3½"x18"

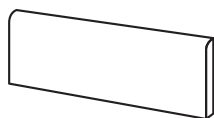

Gradino Step tread
Nez de marche Stufenplatte
cm 30x30 12"x12"

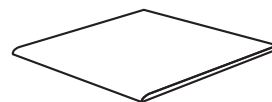

Terminale
Pezzo unico Single piece
Une seule pièce Einzelstück
cm 15x30x3,5 6"x12"x1⅜"

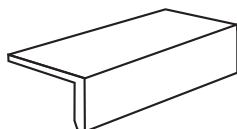

Scalino
e scalino angolare
cm 45x33 18"x13"

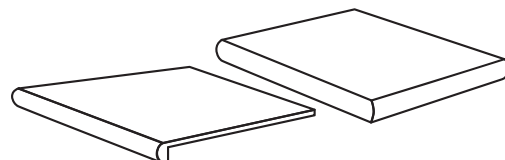

mondo cm 45x45

BEIGE

granitogres rusticato

serie TIBURTINO

tiburtino
beige
cm 15x30



MARMOGRES

MARTE

NUVOLATO

PIETRE RARE

TITANO

AGORÀ

ARDESIA

NATURAL SLATE

PIETRE Runiche

TIBURTINO

tibertino beige

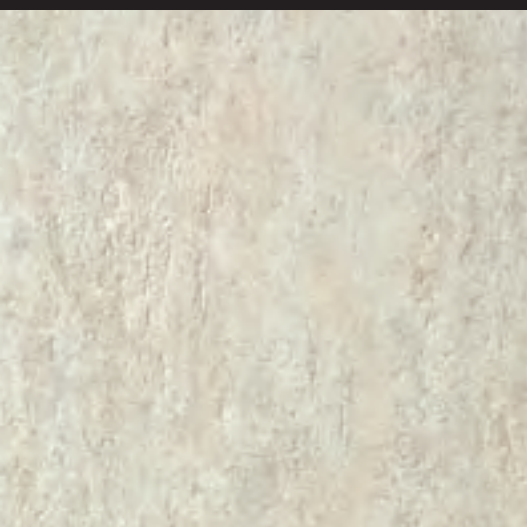
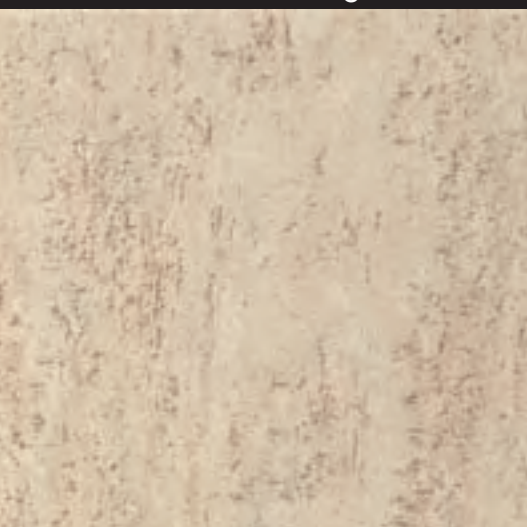

tibertino bianco



tibertino beige
cm 15x15, 15x30, 30x30, 40x40

TABELLA RIASSUNTIVA FORMATI-SUPERFICI-SPESSORI STANDARD
 TABLE SUMMARISING STANDARD SIZES-SURFACES-THICKNESSES
 TABLEAU RECAPITULATIF DES FORMATS-SURFACES-EPAISSEURS STANDARD
 ZUSAMMENFASSENDE TABELLE STANDARD FORMATE-OBERFLÄCHEN-STÄRKEN

granitogres **rusticato**

Formati Sizes Formats Formate	cm 15x15 6"x6"	cm 15x30 6"x12"	cm 30x30 12"x12"	cm 40x40 16"x16"
Superfici Surfaces Surfaces Oberflächen	●	●	●	●
Spessori Thicknesses Epaisseurs Stärken	mm 8,3	mm 8,3	mm 8,3	mm 9

● Naturale Matt Naturelle Natur **R10 A**

PEZZI SPECIALI TRIMS ACCESSOIRES FORMSTÜCKE

Battiscopa Bullnose
 Plinthe à bord arrondi Stehsockel
cm 9x30 3½"x12"
cm 9x40 3½"x16"

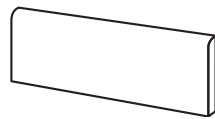

Gradino Step tread
 Nez de marche Stufenplatte
cm 30x30 12"x12"

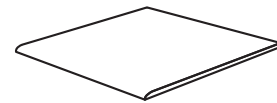

Terminale
cm 15x30x5 6"x12"x2"

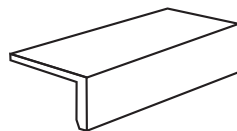

Gradone
 e gradone angolare rusticato
cm 30x30 12"x12"

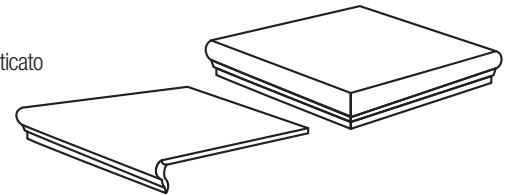

DECORI DECORS DÉCORS DEKORE

FASCIA
 TIBURTINO

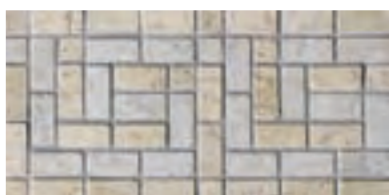

cm 15x30

ANGOLO
 TIBURTINO



cm 15x15

CARATTERISTICHE TECNICHE
 TECHNICAL FEATURES
 CARACTÉRISTIQUES TECHNIQUES
 TECHNISCHE EIGENSCHAFTEN



norma standards
 norme Norm

risultato prova* test results*
 resultats des essais* Ergebnisse*



classificazione prodotto
 product classification
 classement
 Klassifizierung

UNI EN 14411-G
 ISO 13006

gruppo B1a UGL completamente greificato
 group B1a UGL fully vitrified
 group B1a UGL grès cérame fin
 Gruppe B1a UGL Feinsteinzeug



caratteristiche dimensionali e d'aspetto
 dimensional and surface quality
 caractéristiques de la surface
 Oberflächenqualität

UNI EN ISO 10545-2

tolleranze minime nella 1ª scelta
 very low tolerance
 des tolérances minimales en 1er choix
 Entspricht Normen



assorbimento di acqua
 water absorption
 absorption d'eau
 Wasseraufnahme

UNI EN ISO 10545-3

≤ 0,10%



resistenza alla flessione
 flexural strength
 résistance a la flexion
 Biegezug-Festigkeit

UNI EN ISO 10545-4

N/mm² 50÷60



resistenza al gelo
 frost resistance
 résistance au gel
 Frostwiderstandsfähigkeit

qualsiasi norma
 all standards
 toute norme
 Alle normen

garantita
 guaranteed
 garantie
 Frostsicher



resistenza attacco chimico
 (esclusione acido fluoridrico)
 resistance to acids and alkalis
 (with the exception of hydrofluoric acid)
 résistance à l'attaque chimique
 (exclusion de l'acide fluorhydrique)
 Säure und Laugen Beständigkeit
 (mit Ausnahme von Fluorwasserstoff)

UNI EN ISO 10545-13

nessuna alterazione
 no damage
 non attaquées
 Nicht angegriffen



resistenza usura e abrasione
 wear and abrasion resistance
 résistance à l'usure et abrasion
 Abriebhärte

illimitata
 adequate for all purposes
 illimitée
 Unbegrenzt



dilatazione termica lineare
 linear thermal expansion
 coefficient linéaire de dilatation thermique
 Lineare Wärmeausdehnung

UNI EN ISO 10545-8

6 x 10⁻⁶



resistenza alle macchie
 stain resistance
 résistance aux taches
 Fleckenfestigkeit

garantita
 guaranteed
 garantie
 garantiert



resistenza alla scivolosità (Superficie Naturale)
 slip resistance (Matt surface)
 résistance au glissement (Surface naturelle)
 Trittsicherheit (Natur Oberflächen)

DIN 51130

vedere singole serie
 see every series
 voir les séries une par une
 Seihe einzelne Serie



resistenza dei colori alla luce
 light fastness
 résistance de la couleur à la lumière
 Unveränderlichkeit der Farben wenn Strahlung zugesetzt wird

DIN 51094

nessuna variazione
 no change of colours
 couleurs inchangées



Classement upec Surface naturelle
 (serie Marte, Ardesia, Tiburtino)
 (Formats: de 10x20 cm. à 30x30 cm.)

CSTB

U₄ P₄ E₃ C₂

norma ASTM
ASTM standards

risultato prova test results
resultats des essais Ergebnisse

ASTM C-648
breaking strength
≥ 250 lbs

625 lbs**

ASTM C-1026
no sample must show
alterations to surface

resistant

ASTM C-650
no sample must show
alterations to surface

unaffected

ASTM C-1028
NO ANSI
Standard

≥ 0,7 in matt and bocciardato surfaces**

Keinerlei Farbänderung

*valore indicativo approx value donnee approximative Ungefähre Werte **test made on Marte Series

PESI, MISURE E CONTENUTO DEI COLLI
 WEIGHT, SIZE AND CONTENTS OF THE PACKING
 POIDS, DIMENSIONS, CONTENU DES COLIS
 VERPACKUNGSGRÖßEN/GEWICHTE



cm 15x15	6"x6"	8,3	44	0,99	18	64	63,36	1140
cm 15x15	6"x6" <i>Natural Slate</i>	9	40	0,90	21	64	57,60	1210
cm 15x15	6"x6" <i>Pietre Runiche</i>	9	38	0,85	21	64	54,72	1149
cm 15x15	6"x6"	9,5	40	0,90	21,6	64	57,60	1244
cm 15x15	6"x6"	11,3	32	0,72	24	64	46,08	1106
cm 15x30	6"x12"	8,3	22	0,99	18	64	63,36	1140
cm 15x30	6"x12" <i>Natural Slate</i>	9	20	0,90	21	64	57,60	1210
cm 15x30	6"x12" <i>Pietre Runiche</i>	9	19	0,85	21	64	54,72	1149
cm 15x45	6"x18" <i>Natural Slate - Pietre Runiche</i>	9	16	1,08	21	44	47,52	998
cm 15x45	6"x18"	9,5	16	1,08	21,6	44	47,52	1026
cm 15x60	6"x24"	9,5	12	1,08	21,6	40	43,20	933
cm 15x120	6"x48"	10,5	5	0,90	25	48	43,20	1008
cm 20x60	8"x24"	9,5	9	1,08	21,6	48	51,84	1120
cm 20x120	8"x48"	10,5	4	0,96	25	42	40,32	1080
cm 22,5x45	9"x18"	9,5	10	1,012	21,6	51	51,61	1115
cm 30x30	12"x12"	8,3	13	1,17	19	48	56,16	1067
cm 30x30	12"x12" <i>Natural Slate</i>	9	12	1,08	21	48	51,84	1089
cm 30x30	12"x12" <i>Pietre Runiche</i>	9	11	0,99	21	48	47,52	998
cm 30x30	12"x12"	9,5	12	1,08	21,6	48	51,84	1120
cm 30x30	12"x12" <i>levigato polished/honed</i>	9	13	1,17	20	48	56,16	1123
cm 30x30	12"x12"	10,5	11	0,99	25	48	47,52	1188
cm 30x30	12"x12" <i>levigato polished/honed</i>	10	11	0,99	23	48	47,52	1092
cm 30x45	12"x18" <i>Natural Slate - Pietre Runiche</i>	9	8	1,08	21	44	47,52	998
cm 30x45	12"x18"	9,5	8	1,08	21,6	44	47,52	1026
cm 30x60	12"x24"	9,5	6	1,08	21,6	48	51,84	1120
cm 30x60	12"x24" <i>levigato polished</i>	9	6	1,08	20	48	51,84	1037
cm 30x60	12"x24" <i>levigato polished/honed</i>	10	6	1,08	23	48	51,84	1192
cm 30x60	12"x24"	10,5	5	0,90	25	48	43,20	1080
cm 40x40	16"x16" <i>Tiburtino</i>	9	8	1,28	21	48	61,44	1290
cm 40x40	16"x16"	9,5	8	1,28	21,6	48	61,44	1327
cm 40x40	16"x16" <i>levigato polished/honed</i>	9	8	1,28	20	48	61,44	1289
cm 45x45	18"x18" <i>Natural Slate - Pietre Runiche</i>	9	5	1,012	21	34	34,41	723
cm 45x45	18"x18"	9,5	5	1,012	21,6	34	34,41	743
cm 60x60	24"x24" <i>naturale matt/satinato satin finished</i>	10,5	4	1,44	25	30	43,20	1080
cm 60x60	24"x24" <i>levigato polished/honed</i>	10	4	1,44	23	30	43,20	994
cm 60x120	24"x48" <i>naturale matt/satinato satin finished</i>	10,5	2	1,44	25	24	34,56	864
cm 60x120	24"x48" <i>levigato polished</i>	10	2	1,44	23	24	34,56	795

BATTISCOPA B.C. BULLNOSE PLINTE A BORD ARRONDI STEHSCOCKEL

cm 9x30	3/2" x12" <i>Agorà - Ardesia - Tiburtino</i>	30	-	-	-	-	-
cm 9x30	3/2" x12"	28	-	-	-	-	-
cm 9x30	3/2" x12" <i>Pietre Runiche</i>	27	-	-	-	-	-
cm 9x40	3/2" x16"	22	-	-	-	-	-
cm 9x45	3/2" x18"	18	-	-	-	-	-
cm 9x60	3/2" x24"	18	-	-	-	-	-

GRADINO STEP TREAD NEZ DE MARCHE STUFENPLATTE

cm 30x30	12"x12" <i>Agorà - Ardesia - Tiburtino</i>	13	-	-	-	-	-
cm 30x30	12"x12" <i>levigato polished</i>	14	-	-	-	-	-
cm 30x30	12"x12"	12	-	-	-	-	-
cm 30x30	12"x12" <i>Marmogres - Pietre Runiche</i>	11	-	-	-	-	-
cm 30x60	12"x24" <i>Marte - Pietre Rare - Titano</i>	6	-	-	-	-	-
cm 30x60	12"x24" <i>Marmogres</i>	5	-	-	-	-	-

PESI, MISURE E CONTENUTO DEI COLLI
 WEIGHT, SIZE AND CONTENTS OF THE PACKING
 POIDS, DIMENSIONS, CONTENU DES COLIS
 VERPACKUNGSGRÖßEN/GEWICHTE

granitogres



GRADINO STEP TREAD NEZ DE MARCHE STUFENPLATTE

cm 40x40	16"x16"	8	-	-	-	-	-
cm 45x45	18"x18"	5	-	-	-	-	-

SCALINO

cm 40x33	16"x13"	4	-	-	-	-	-
cm 45x33	18"x13"	4	-	-	-	-	-
cm 60x33	24"x13" <i>Marmogres</i>	6	-	-	-	-	-

SCALINO ANGOLARE

cm 40x33	16"x13"	3	-	-	-	-	-
cm 45x33	18"x13"	3	-	-	-	-	-
cm 60x33	24"x13" <i>Marmogres</i>	4	-	-	-	-	-

GRADONE

cm 25x33	10"x13"	5	-	-	-	-	-
cm 30x33	12"x13"	4	-	-	-	-	-
cm 60x33	24"x13"	4	-	-	-	-	-

GRADONE ANGOLARE

cm 25x33	10"x13"	5	-	-	-	-	-
cm 30x33	12"x13"	2	-	-	-	-	-
cm 60x33	24"x13"	2	-	-	-	-	-

GRADONE RUSTICATO

cm 30x30	12"x12"	4	-	-	-	-	-
----------	---------	---	---	---	---	---	---

GRADONE ANGOLARE RUSTICATO

cm 30x30	12"x12"	2	-	-	-	-	-
----------	---------	---	---	---	---	---	---

GRADONE TORO

cm 60x33	24"x13"	1	-	-	-	-	-
cm 60x33	24"x13"	1	-	-	-	-	-
<i>[con bordo antiscivolo step treadstep with non-slip edging marche avecnez antidérapant Stufenplatte mit rutschsicherer Kante]</i>							
cm 120x33	48"x13"	1	-	-	-	-	-

ANGOLARE TORO

cm 60x33	24"x13"	1	-	-	-	-	-
cm 120x33	48"x13"	1	-	-	-	-	-

ZOCCOLO SKIRTING PLINTHE HOHLKEHLSOCKEL

cm 15x30	6"x12"	12	-	-	-	-	-
cm 3x15	1"x6" <i>A7 - S7</i>	10	-	-	-	-	-

TOZZETTO INSERT CABOCHON EINLEGER

cm 9x9	3 1/2"x3 1/2" <i>Marte - Marmogres - Pietre Rare - Titano</i>	33	-	-	-	-	-
--------	---	----	---	---	---	---	---

LISTELLO LISTEL LISTEL ZEIERLEISTE

cm 9x30	3 1/2"x12" <i>Marte - Marmogres - Pietre Rare - Titano</i>	28	-	-	-	-	-
cm 9x40	3 1/2"x16"	22	-	-	-	-	-
cm 9x60	3 1/2"x24"	18	-	-	-	-	-

TERMINALE STEP TREAD REBORD BECHKENRANDPLATTE

cm 15x30x3,5	6"x12"x1 1/2"	6	-	-	-	-	-
cm 15x30x5	6"x12"x2"	8	-	-	-	-	-



POSA IN OPERA

La riuscita di un pavimento è dovuta non solo alla qualità delle piastrelle, ma a tutto un insieme di elementi (sottofondo, strato legante, giunti di dilatazione, ecc.) che costituiscono un vero e proprio sistema. Ecco perché le operazioni di posa sono da considerarsi importanti tanto quanto la scelta delle piastrelle.

È comunque compito del progettista stabilire, in funzione della struttura e della destinazione d'uso del piano di calpestio, il corretto modo di applicazione delle piastrelle e il tipo di piastrella da utilizzare. **Granitogres**, **Pietre Native** e **Granitoker** non si differenziano, per quanto riguarda le operazioni di posa, da una qualsiasi altra ceramica e si può quindi seguire sia il sistema tradizionale con malta cementizia, che quello con collanti o adesivi.

Prima di iniziare le operazioni di posa di una qualsiasi superficie si raccomanda di accertarsi che la partita di grès sia adeguata e sufficiente per quantità, tono e calibro, a quella necessaria.

Si dovranno poi seguire tutte le norme e le precauzioni che sono alla base di una corretta esecuzione del lavoro (preparazione del sottofondo, composizione della malta o dei collanti, tempi di maturazione, posizionamento dei giunti di dilatazione, battitura, ecc.). Se per ambienti di grandi dimensioni è assolutamente necessario posizionare i giunti con regolarità, per piccoli ambienti è sufficiente lasciare un leggero stacco fra piastrellato e muri perimetrali. Sarà poi il battiscopa a coprire lo stacco dando un aspetto di finitura. Evitare il transito sul pavimento per almeno 2/3 giorni dopo la posa. In caso di necessità di transito si dovrà predisporre un tavolato appoggiato sul pavimento.

Tenere presente che, nel caso di posa col sistema tradizionale e in mancanza di particolari additivi nella malta, è necessario attendere anche un mese prima di sottoporre il pavimento a sollecitazioni e carichi di esercizio.

Granitogres, **Pietre Native** e **Granitoker**, pur essendo materiali molto resistenti, possono essere facilmente sagomati o perforati per l'installazione di impianti tecnico-sanitari.

MANUTENZIONE E PULIZIA

Un pavimento o rivestimento murale in **Granitogres**, **Pietre Native** e **Granitoker** sia nella versione naturale che satinata o levigata è sinonimo di bellezza, durata e resistenza nel tempo oltre che di facilità di manutenzione. La sua manutenzione non richiede infatti particolari cure se non le seguenti norme di pulizia.

Prima pulizia. Si esegue normalmente una sola volta prima dell'utilizzo del pavimento e deve essere obbligatoriamente eseguita dopo la posa in opera. Ha lo scopo di eliminare ogni traccia di calce, cemento o residui di resine contenute negli stucchi per le fughe; in questa fase tutte le tipologie di prodotto Casalgrande Padana devono essere lavate con una soluzione di acido muriatico (2/3 di acqua, 1/3 di acido) o prodotti similari appositamente studiati quali Deterprimo (Casalgrande Padana), Deterdek (Fila), Keranet (Mapei), Deltaplus (Kerakoll), Viakal (Procter&Gamble). (*)

Per evitare che il prodotto, a base acida, usato per la prima pulizia, vada ad intaccare il riempimento a base cementizia delle fu-

ghe, si consiglia, prima della suddetta operazione, di bagnare il pavimento affinché le fughe vengano impregnate e pertanto protette dall'azione corrosiva dell'acido stesso. Se la prima pulizia viene eseguita dopo che il pavimento è stato usato, sarà bene, prima dell'applicazione del prodotto acido, togliere con appositi detersivi eventuali presenze di sostanze grasse o simili.

Dopo la pulizia occorre risciacquare abbondantemente il pavimento e raccogliere l'acqua residua.

Pulizia ordinaria. Per la pulizia di tutti i giorni è sufficiente lavare il pavimento con acqua e aggiunta di normali prodotti detergenti adatti a pulire superfici ceramiche.

La superficie di **Granitogres**, **Pietre Native** e **Granitoker** essendo praticamente inassorbente, **non richiede l'applicazione di cere e/o prodotti analoghi di protezione che, al contrario, non debbono mai essere usati.** Il gres non trattiene macchie o aloni di qualsiasi genere; in presenza tuttavia di macchie persistenti e difficili da togliere con la pulizia ordinaria, esse si possono eliminare con impiego appropriato di detergenti più forti e più concentrati in grado di rimuovere lo sporco più intenso e di ricondurre le piastrelle all'aspetto originario. Al riguardo è opportuno segnalare che il grès è resistente a qualsiasi sostanza chimica, **eccezione fatta per l'acido fluoridrico che attacca tutti i prodotti ceramici.**

SUPERFICIE GLOSS E LEVIGATA

Come è noto tutte le superfici lucide subiscono con l'uso un processo di opacizzazione. Nel caso di **Granitogres**, **Pietre Native** e **Granitoker** grazie alle peculiari caratteristiche tecniche, questo processo è più lento rispetto a qualsiasi altro materiale naturale (marmo, granito, pietre...). Per conservare tuttavia il più a lungo possibile la lucentezza originale del pavimento è bene proteggere l'ingresso del locale pavimentato, specie se questo è in diretta comunicazione con ambienti esterni, con uno zerbino che possa trattenere il più possibile polveri o altre sostanze abrasive fuori dal pavimento.

RIVESTIMENTI ESTERNI

Per rivestimenti esterni di facciate Casalgrande Padana è a disposizione con il proprio ufficio tecnico per suggerire le soluzioni più idonee e per fornire una eventuale assistenza alla progettazione e alla posa.

PAVIMENTI SOPRAELEVATI

Granitogres, **Pietre Native** e **Granitoker** per le sue caratteristiche fisico-meccaniche e in particolare per la elevatissima resistenza meccanica sia a flessione che a compressione, resistenza all'urto e all'abrasione, è particolarmente indicato anche per pavimentazioni sopraelevate. In questo caso l'ufficio tecnico Casalgrande Padana è in grado di offrire tutta l'assistenza necessaria per le soluzioni di ogni problema.

(*) Per la serie Metallica (articoli Inox, Ferro, Nichel, Rame, Zinco Titanio),



INSTALLATION AND MAINTENANCE

INSTALLATION

The successful installation of floors depends not only on the quality of tiles but on a combination of factors (bedding, binding layer, expansion joints, etc.) that constitute a real system.

That is why installation operations are to be considered as important as the choice of tiles. However, based on the structure and purpose of the flooring surface, the designer is still responsible for defining the correct procedure to lay the tiles and selecting the ones to be employed. When it comes to installation operations, **Granitogres**, **Pietre Native** and **Granitoker** do not differ from any other type of ceramic: either the traditional procedure envisaging cement mortar or the procedure envisaging glues and adhesives may be resorted to.

Before starting the installation operations of any surface, we recommend you make sure that the stoneware batch is adequate and sufficient in terms of quantity, tone and calibration. Moreover, all necessary norms and precautions need to be implemented for the correct completion of the work (bedding preparation, composition of mortar or adhesives, maturing period, positioning expansion joints, ramming, etc.).

If in case of large environments joints must be positioned at regular intervals, in small environments a small gap between the tiles and perimeter walls is sufficient: the skirting board will cover the gap and provide the finishing effect.

Avoid walking on the floor for at least 2/3 days after installation. If walking on the floor is necessary, lay wooden planks on the surface. Please notice that if the tiles are installed with the traditional procedure and no additives are added to the mortar, at least one month has to elapse before the floor can be subjected to stress and operating loads.

Even though **Granitogres**, **Pietre Native** and **Granitoker** are very resilient materials, they can easily be shaped or perforated to install technical and sanitary systems.

MAINTENANCE AND CLEANING

Granitogres, **Pietre Native** and **Granitoker** floor and wall cladding, both in their natural and brushed or honed versions, ensure beauty, long life and resistance in time, in addition to easy maintenance. Maintenance does not require specific treatment with the exception of the following cleaning instructions.

Initial cleaning. It is normally performed once before using the floor and it is obligatorily performed after installation. Its purpose is to eliminate any trace of lime, cement or resin residues contained in the grouts used for the joints.

During this phase, all the typologies of Casalgrande Padana products must be washed using a solution of hydrochloric acid (2/3 water, 1/3 acid) or similar products specially designed for this purpose, such as Deterprimo (Casalgrande Padana), Deterdek (Fila), Keranet (Mapei), Deltaplus (Kerakoll), Viakal (Proctel&Gamble). (*)

To prevent the acid-based product used for the initial cleaning from corroding the cement-based joint filler, we recommend you wet the floor prior to cleaning so that the joints are impreg-

nated and thus protected from the corrosive action of the acid. If the initial cleaning is carried out after the floor has been used, before applying the acid product it is advisable to first remove any greasy or similar substances using suitable cleaning products.

After cleaning, the floor must be rinsed thoroughly and the residual water collected.

Routine cleaning. For everyday cleaning, simply wash the floor with water and normal cleaning products suitable for ceramic surfaces.

The **Granitogres**, **Pietre Native** and **Granitoker** surface is practically impervious and therefore **does not require the application of wax and/or analogous protective products which, on the contrary, should never be used.**

Stoneware does not retain stains or smudges of any type. Nonetheless, persistent stains that are difficult to remove with normal cleaning may be eliminated with the appropriate use of stronger and more concentrated cleaning products, capable of removing heavier dirt and restoring the original appearance of the tiles.

In this respect, we should point out that stoneware is resistant to all chemicals, with the exception of hydrofluoric acid, which is harmful to all ceramic products.

GLOSS AND POLISHED SURFACE

As is well known, all shiny surfaces become more opaque with use. In the case of **Granitogres**, **Pietre Native** and **Granitoker**, the particular technical features make this process slower than it is for any other natural material (marble, granite, stone...). Nonetheless, to preserve the original sheen of the floor as long as possible, it is advisable to protect the entrance to the room, especially if it is in direct communication with outdoor areas, using a door mat that will as much as possible keep dust or other abrasive substances away from the floor.

EXTERNAL WALLS CLADDING

For external walls cladding the technical department of Casalgrande Padana is at customers' disposal in order to suggest the most suitable solution and to provide necessary assistance.

RAISED FLOORS

Granitogres, **Pietre Native** and **Granitoker**, thanks to their high mechanical characteristics such as flexural resistance, compression resistance, impact resistance, wearing resistance, are extremely suitable for raised floors. In this case too the technical department of Casalgrande Padana is at customers' disposal to provide necessary assistance.

(*) For the Metallica series (Inox, Ferro, Nichel, Rame, Zinco Titanio) use a more diluted solution (e.g. 9 parts of water and 1 part of acid)



POSE

Un bon sol dépend non seulement de la qualité des carreaux, mais aussi de toute une série d'éléments qui constituent un seul tout (couche de fond, couche d'un agent liant, joints de dilatation, etc.). C'est pourquoi les opérations de pose sont tout aussi importantes que le choix du carrelage. Il appartient à l'architecte d'établir le type de carrelage à utiliser en fonction du lieu et de l'utilisation du sol ainsi que la meilleure méthode de pose des carreaux. En ce qui concerne les opérations de pose, les séries **Granitogres**, **Pietre Native** et **Granitoker** ne sont pas différentes des autres carreaux céramiques et il est donc possible de suivre la méthode traditionnelle en utilisant du mortier de ciment ou d'utiliser des colles ou autres produits adhésifs. Avant de commencer les opérations de pose, il est recommandé de vérifier que les lots de carreaux en grès correspondent bien à la quantité, à la couleur et au calibre nécessaires. Il faut ensuite respecter toutes les normes et les précautions qui sont à la base de la bonne exécution des travaux (préparation de la couche de fond, composition du mortier ou des colles, positionnement des joints de dilatation, nivellement à l'aide du maillet, temps de séchage, etc.).

Pour les grandes surfaces, il est absolument nécessaire de positionner les joints avec la plus grande régularité, tandis que pour les petites surfaces, il suffira de laisser un léger écart entre le carrelage et les murs périmétraux.

Ce seront ensuite les plinthes qui couvriront l'écart pour donner l'aspect de finition. Après la pose, éviter de marcher sur le sol pendant au moins 2 ou 3 jours. Si le passage s'avère nécessaire, il faudra poser des planches sur le sol. Ne pas oublier qu'en cas de pose en suivant la méthode traditionnelle et en absence d'additifs particuliers dans le mortier, il faut attendre même un mois avant de soumettre le sol à toute charge et/ou sollicitation. Même si les carreaux des séries **Granitogres**, **Pietre Native** et **Granitoker** sont extrêmement résistants, ils sont faciles à façonner et à perforer pour installer les équipements technico-sanitaires.

ENTRETIEN ET NETTOYAGE

Un revêtement de sol ou de mur en **Granitogres**, **Pietre Native** et **Granitoker** dans les versions naturelles, satinées et polies, est synonyme non seulement de beauté, de solidité et de durabilité, mais aussi de facilité d'entretien.

En effet, aucune opération particulière n'est exigée pour son entretien. Il suffit d'appliquer les conseils de nettoyage suivants.

Premier nettoyage. À effectuer normalement une seule fois avant d'utiliser le sol et il faut l'effectuer obligatoirement après la pose. Son but est d'éliminer les traces de chaux et de ciment ou les résidus de résines contenus dans les ciments-colles utilisés pour le jointoiment. Pendant cette phase, toutes les typologies de produits Casalgrande Padana doivent être lavées avec une solution d'acide muriatique (1/3 d'acide, 2/3 d'eau) ou en utilisant des produits similaires spécifiques tels que Deterprimo (Casalgrande Padana), Deterdek (Fila), Keranet (Mapei), Delta-plus (Kerakoll), Viakal (Procter&Gamble). (*)

Afin d'éviter que le produit à base acide utilisé lors du premier nettoyage ne puisse attaquer le joint à base de ciment, il est conseillé de mouiller le sol avant d'effectuer cette opération, afin que les joints soient bien imprégnés d'eau en les protégeant ainsi de l'action corrosive de l'acide.

Si le premier nettoyage est exécuté après avoir marché sur le sol, avant d'appliquer le produit acide il faudra éliminer toute éventuelle trace de substances grasses ou similaires en utilisant les nettoyeurs prévus à cet effet. Après le nettoyage, rincer le sol à grande eau, puis éliminer toute trace d'eau.

Nettoyage ordinaire. Pour le nettoyage quotidien, il suffit de laver le sol avec de l'eau et des détergents adaptés aux surfaces céramiques. Les carrelages en **Granitogres**, **Pietre Native** et **Granitoker** étant pratiquement non absorbants, **il n'est pas nécessaire de passer des cires et/ou autres produits de protection similaires, produits qui bien au contraire ne doivent jamais être utilisés.** Les grès ne retiennent ni les taches ni les auréoles, quelle qu'en soit l'origine. Néanmoins, en cas de taches persistantes et difficiles à éliminer par un nettoyage ordinaire, utiliser un détergent plus puissant et plus concentré en mesure d'éliminer les impuretés et d'aider le carrelage à retrouver son aspect original. **Il est intéressant de signaler que le grès résiste aux substances chimiques, à l'exception de l'acide fluorhydrique qui attaque tous les produits céramiques.**

SURFACE GLOSS ET POLIE

Il est reconnu que les surfaces polies ont tendance à se ternir dans le temps. Dans le cas de **Granitogres**, **Pietre Native** et **Granitoker**, leurs caractéristiques techniques particulières permettent de ralentir ce processus par rapport à tout autre matériau naturel (marbre, granit, pierres...). Pour garder le plus longtemps possible l'éclat original de votre sol, il est toutefois conseillé de protéger l'entrée de la pièce, surtout si celle-ci est en communication directe avec l'extérieur, en plaçant un paillason qui empêchera le plus possible les poussières ou toutes autres substances abrasives d'endommager le sol.

REVÊTEMENTS EXTÉRIEURS

Pour les revêtements extérieurs de façades Casalgrande Padana met à votre disposition son bureau technique pour vous conseiller les solutions les plus appropriées et pour vous offrir son assistance en phase de projet et de pose.

PLANCHERS TECHNIQUES

Granitogres, **Pietre Native** et **Granitoker** grâce à ses caractéristiques physico-mécaniques et en particulier à sa très haute résistance mécanique à la flexion et à la compression, la résistance au choc et à l'abrasion, est tout particulièrement indiqué pour les planchers techniques. Dans ce cas le bureau technique Casalgrande Padana est en mesure d'offrir toute l'assistance nécessaire pour trouver une solution à chaque problème.

(*) Pour la série **Metallica** (articles **Inox**, **Ferro**, **Nichel**, **Rame**, **Zinco-Titanio**), utiliser une solution plus diluée (par exemple, 1/10° d'acide et 9/10° d'eau)



VERLEGEN UND PFLEGE

VERLEGUNG

Das gute Gelingen einer Bodengestaltung hängt nicht nur von der Qualität der Fliesen ab, sondern von einer ganzen Reihe Elemente (Untergrund, Bindschicht, Dehnungsfugen, usw.), die ein Gesamtsystem bilden. Deshalb sind die Verlegungsarbeiten genauso wichtig wie die Wahl der Fliesen. Es ist die Aufgabe des Planers, in Funktion der Struktur und des Bestimmungszweckes der Bodenfläche die korrekte Fliesenanbringungsmethode und die Art der einzusetzenden Fliesen zu bestimmen.

Granitogres, Pietre Native und **Granitoker** unterscheiden sich in Bezug auf die Verlegungsarbeiten nicht von jeder anderen Keramik, sodass die Verlegung sowohl mit dem traditionellen Zementmörtelsystem als auch mit Leimen oder Klebstoffen erfolgen kann. Vor Beginn der Verlegung auf irgendwelchen Oberflächen ist unbedingt sicher zu stellen, dass das Steinzeug geeignet ist und in der notwendigen Menge und im gewünschten Farbton und Werkmaß zur Verfügung steht.

Daraufhin sind alle Vorschriften und Vorkehrungen zu befolgen, die einer korrekten Ausführung der Arbeiten zu Grunde liegen (Vorbereitung des Untergrundes, Zubereitung des Mörtels oder der Kleber, Abbindezeiten, Position der Dehnungsfugen, Anklappen, usw.). In großflächigen Bereichen sind die Dehnungsfugen unbedingt regelmäßig einzuplanen, während es in kleinen Bereichen genügt, ein wenig Abstand zwischen Fliesenfläche und Randmauern zu lassen. Mit der Sockelleiste wird dieser Abstand dann abgedeckt, um den Boden fertig zu stellen. Nach dem Verlegen darf der Boden mindestens 2-3 Tage nicht begangen werden. Falls ein Begehen notwendig sein sollte, sind vorher Bretter auf den Boden zu legen.

Es ist zu berücksichtigen, dass es bei der Verlegung mit dem traditionellen System und ohne spezielle Zusatzstoffe im Mörtel notwendig ist, noch einen Monat zu warten, bevor der Boden Beanspruchungen und Betriebslasten ausgesetzt wird. Trotzdem es sich bei **Granitogres, Pietre Native** und **Granitoker** um hochresistente Materialien handelt, lassen sich die Platten für die Installation technisch-sanitärer Anlagen leicht formen oder bohren.

INSTANDHALTUNG UND REINIGUNG

Ein Bodenbelag oder eine Wandverkleidung aus **Granitogres, Pietre Native** und **Granitoker** ist sowohl in der natürlichen wie auch satinierten oder polierten Ausführung der Ausdruck von Schönheit, dauerhafte Resistenz und Langlebigkeit, sowie Pflegefreundlichkeit.

Für die Instandhaltung sind abgesehen von den folgenden Reinigungsvorschriften tatsächlich keine besonderen Regeln gesetzt.

Erstreinigung. Wird normalerweise ein einziges Mal vor der Verwendung des Bodens durchgeführt und ist obligatorisch nach der Verlegung vorzunehmen. Sie hat die Aufgabe, jede Spur von Kalk, Zement oder Harzrückständen aus den Fugenfüllern zu entfernen; in dieser Phase sind alle Produkte von Casalgrande Padana mit einer Salzsäurelösung (2/3 Wasser, 1/3 Säure) oder spezifisch entwickelten ähnlichen Produkten wie Deterprimo (Casalgrande Padana), Deterdek (Fila), Keranet (Mapei), Delta-

plus (Kerakoll), Viakal (Procter&Gamble) zu waschen. (*)

Um zu vermeiden, dass das für die Erstreinigung verwendete Produkt auf Säurebasis die Fugenfüllung auf Zementbasis angreift, wird empfohlen, den Boden vor diesem Arbeitsgang zu nassen, damit die Fugen imprägniert werden und dadurch vor der korrodierenden Wirkung der Säure geschützt sind. Falls die Erstreinigung auf einem bereits benutzten Boden durchgeführt wird, sollten vor dem Auftragen des säurehaltigen Produkts eventuell vorhandene Fettstoffe oder dergleichen mit geeigneten Reinigungsmitteln entfernt werden. Nach der Reinigung ist der Boden ausgiebig nachzuspülen und die Wasserrückstände aufzunehmen.

Unterhaltsreinigung. Für die tägliche Reinigung genügt eine Bodenwäsche mit Wasser und einem normalen Reinigungsmittel für Keramikflächen. Die Oberflächen aus **Granitogres, Pietre Native** und **Granitoker** sind praktisch nicht absorbierend und **verlangen kein Auftragen von Wachs und/oder ähnlichen Schutzmitteln, die im Gegenteil nie verwendet werden dürfen.** Steinzeug nimmt keinerlei Flecken bzw. Schlieren auf; sollten jedoch hartnäckige Flecken vorhanden sein, die sich mit der Normalreinigung nicht entfernen lassen, können in angemessener Weise stärkere und konzentriertere Reinigungsmittel verwendet werden, die den stärksten Schmutz entfernen und den Fliesen ihr ursprüngliches Aussehen wieder zurück erstatten. **Diesbezüglich ist zu erwähnen, dass Steinzeug gegen alle chemischen Mittel beständig ist, außer gegen Fluorwasserstoff, der alle keramischen Produkte angreift.**

GLOSS UND POLIERTE OBERFLÄCHEN

Für die alltägliche Reinigung reicht es aus, den Bodenbelag mit einer Lösung aus Wasser und einem handelsüblichen Reinigungsmittel für Keramikböden abzuwaschen. Die Oberfläche des **Granitogres, Pietre Native** und **Granitoker** ist praktisch wasserabweisend und muss daher nicht mit Wachsen bzw. Um den ursprünglichen Glanz des Bodenbelags jedoch möglichst lange zu erhalten, sollte man den Eingang des Raums, der mit diesem Bodenbelag ausgekleidet ist - insbesondere, wenn er direkt nach draußen führt - mit einem Fußabstreifer schützen, auf dem Staub und andere abrasive Stoffe größtenteils zurück gehalten werden.

AUßENVERKLEIDUNGEN

Für die Verkleidung von Fassaden steht Ihnen das technische Büro von Casalgrande Padana zur Verfügung, um die geeignetste Lösung zu finden und um eventuell auch bei der Planung und Verlegung mitzuhelfen.

DOPPELBÖDEN

Granitogres, Pietre Native, Granitoker ist aufgrund seiner mechanischen Produkteigenschaften und insbesondere seiner Widerstandsfähigkeit gegen Abnutzung, Bruch und Druck, Schlag- und Kratzfestigkeit besonders für Doppelböden geeignet. In diesem Fall kann Ihnen das technische Büro von Casalgrande Padana die notwendige Unterstützung bei der Lösung aller Probleme anbieten.

(*) Für die Serie Metallica (Artikel Inox, Ferro, Nickel, Rame, Zinco Titanio)

GRANITOGRES

GRES FINE PORCELLANATO

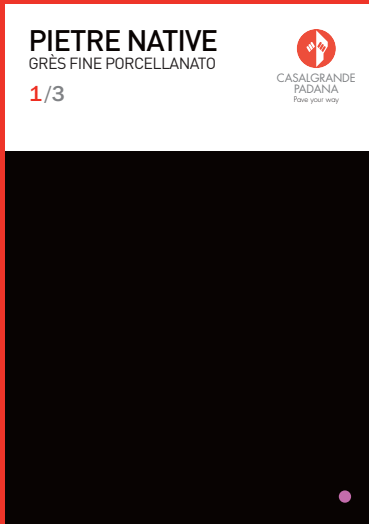

1/3

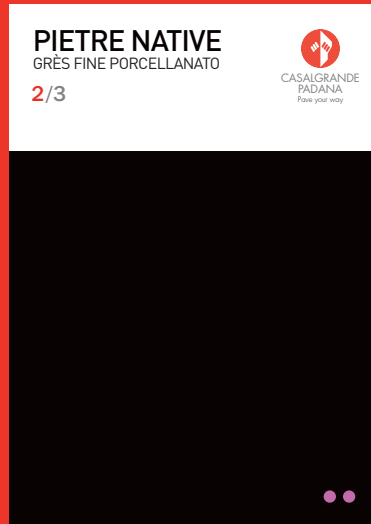

2/3

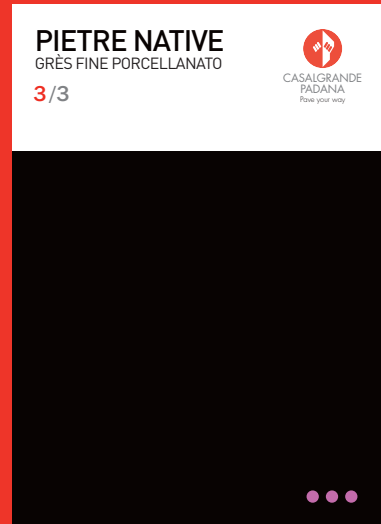

3/3

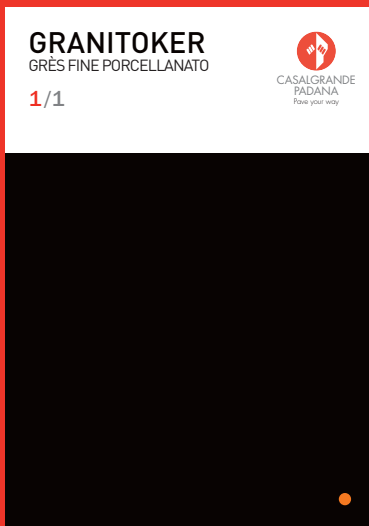

1/1

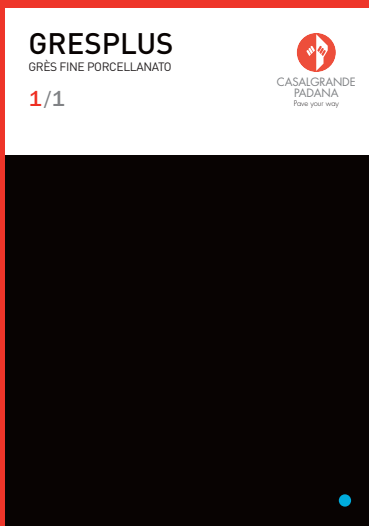

1/1

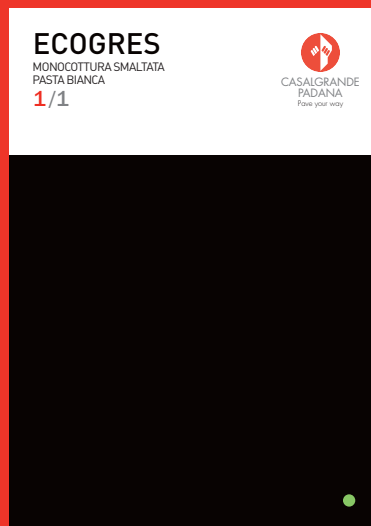

1/1



CASALGRANDE
PADANA

Pave your way

via Statale 467, n. 73, 42013 Casalgrande (Re), Italy
tel + 39 0522 9901, fax + 39 0522 996121
info@casalgrandepadana.it **www.casalgrandepadana.com**